

V1.1 Bike Controller Module

Installation Manual

REV 1

Rae-San

10/06/2023

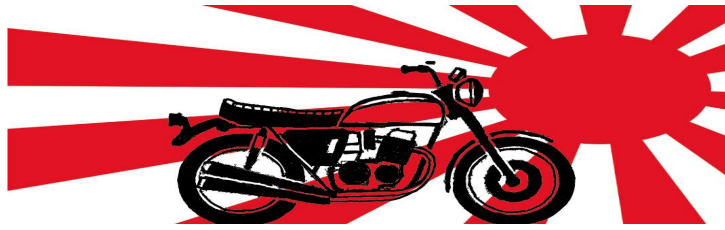

Rae-San V1.0 Bike Controller Module

Congratulations on your purchase of the Rae-San Bike Control module.

The module is designed to offer a cost-effective means to minimise the wiring on your bike and allow for custom builds, while offering all the basic functions and a couple of extras.

I wanted a general unit that would accept programmable input polarities from standard controls, and provide the control outputs with a few whistles -

- Adjustable and selectable Brake flash
- Adjustable and selectable indicator time out
- Low beam modulator able to be turned on or off if enabled
- The ability to use the Harley Davidson style button push left and right indicator controls -so the ability to latch inputs as well as use the standard on/off controls.
- Selectable gate function to enable/disable starter activation with side stand, gear selection or other input.
- Kill switch / ignition power control'
- Integrated power control - No relays other than Starter Solenoid / relay
- **ZERO** power draw when off.

- built in heated grip control - using the existing controls. -
 - programmable number of heat steps / enable disable
 - Short press of start button with clutch/gate switch deactivate - up a step (cycles around)
 - Long press of start button with clutch/gate switch deactivated - turn on / off
 - Starter press with clutch/Gate active - normal starter function
- 4 button control mode
 - instead of the standard controls - all functions can be activated with 4 buttons - in the recommended layout of an up and down button on each handlebar -
 - the 4-button control has a selection of 4 preprogrammed button function mappings that are chosen from the setup menu - but they are implanted in a simple mapping table in the code making changes / customisation a very simple matter.
 - button activations are short press (< 0.6s), double short press (2 press within 0.8s), medium press (1-3s) and long press (3-10s).

I had a look at the resettable fuse option - but it adds more cost and complexity than its worth - so instead - used 30A mostets with two main circuits of master fuse (e.g., 2x10A) or you can fuse the individual outputs if desired.

Setup is via a simple serial terminal setup.

The software is written in a modular fashion and shouldn't be too hard for people with some experience to follow.

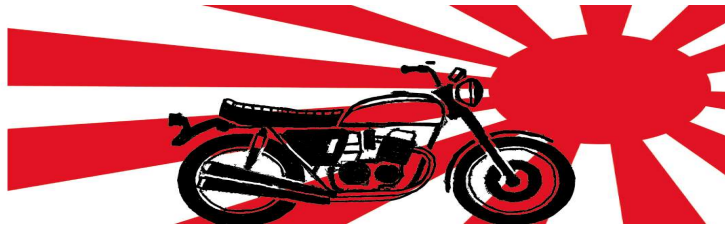

Your module should look like the picture on the left – the picture on the right shows the internal view. Most of the electronics is buried under the controller – and on the underside of the bottom board.

The system is built on the Arduino Nano platform and the source code is open and available for download should you wish to customise something to your own need or want to implement some other special function.

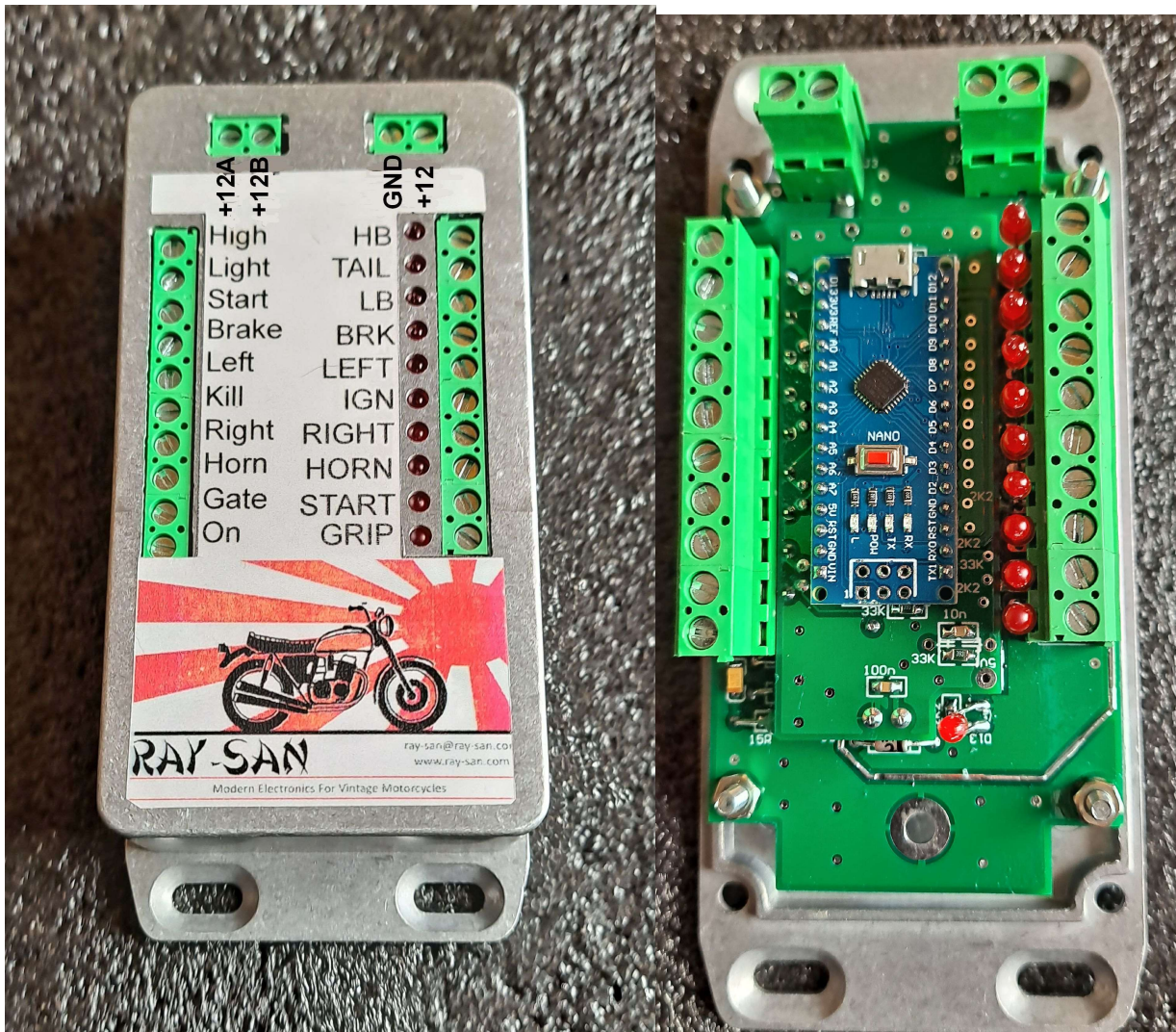

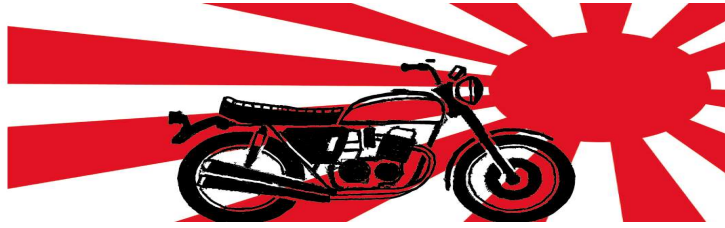

INPUTS

All inputs have pull up resistors so they can sense when pulled low without additional components needing to be added.

On inputs that need to float low and are pulled high when active the appropriate resistor can be snipped with a pair of side-cutters to avoid the pull-up function. The resistors for each are labelled below.

If you wire the controls such that that all buttons pull to ground, then there is no need to snip anything, but the flexibility is there if needed if you have controls that pull high.

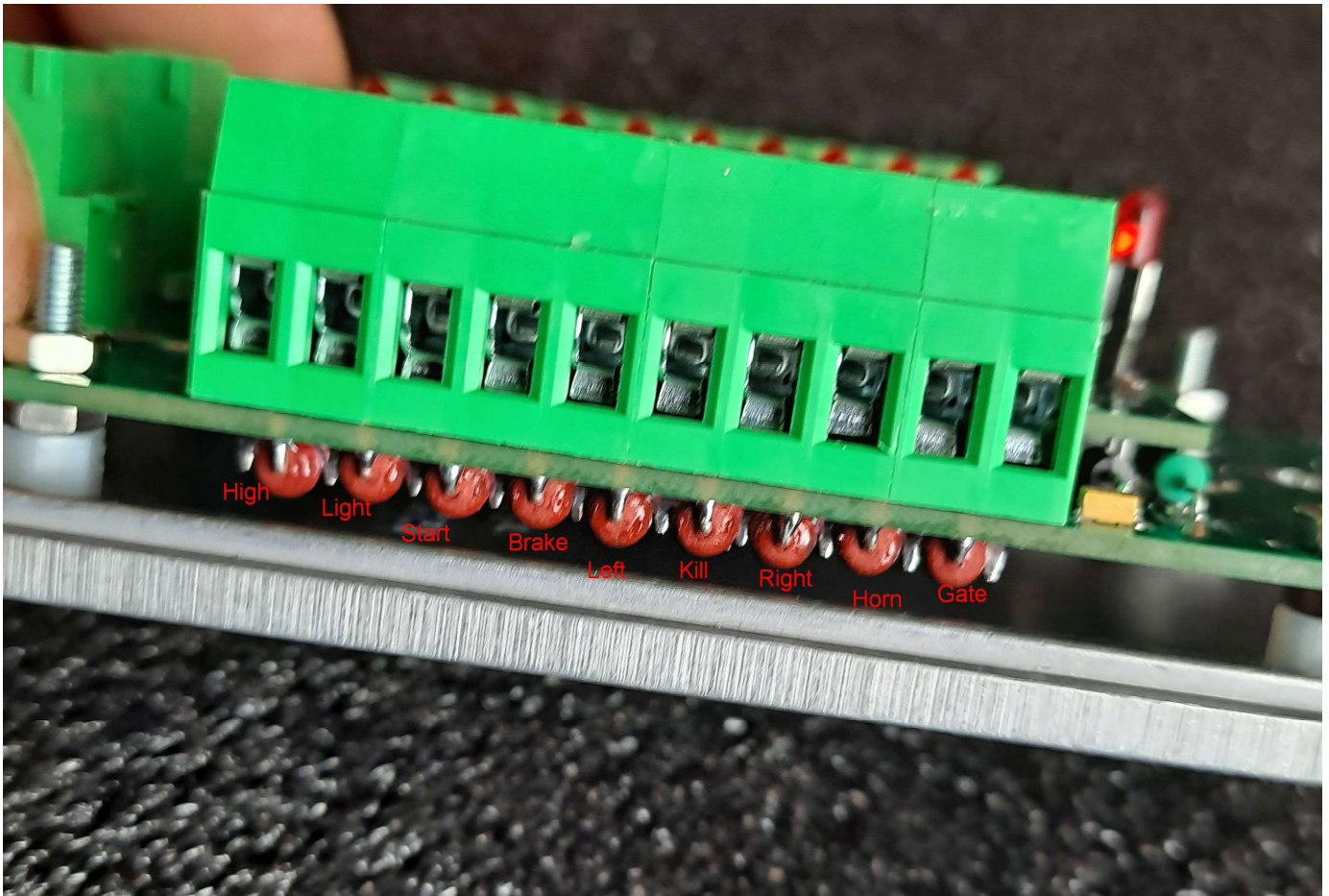

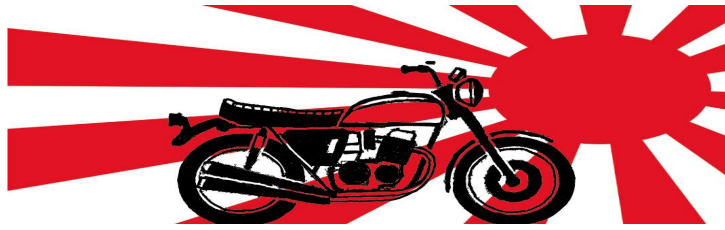

Input Functions

The Normal Function indicates the input function in standard control mode, and the 4-button function is for when operating with the 4-button input mode. Polarity indicates TRUE - +12V is read as an Active/ON state, or if FALSE is selected, the input is sensed ACTIVE LOW- where 0V is input ON.

The usual settings for each mode are indicated.

Input	Normal function	4 button function	Polarity	Normal usual Polarity	4 Button usual Polarity
High	High Beam Switch Sense Input	Left UP	True – On = +12 False – On = 0V	T	F
Light	Lights On Switch Sense Input	No Connect	True – On = +12 False – On = 0V	T	T
Start	Starter Button Sense Input	Right DOWN	True – On = +12 False – On = 0V	T	F
Brake	Brake Active Sense Input	No connect	True – On = +12 False – On = 0V	T	T
Left	Left Indicator Switch Sense Input	No Connect	True – On = +12 False – On = 0V	T	T
Kill	Kill Switch Sense Input	Right UP	True – On = +12 False – On = 0V	F	F
Right	Right Indicator Switch Sense Input	No Connect	True – On = +12 False – On = 0V	T	T
Horn	Horn Switch Sense Input	Left DOWN	True – On = +12 False – On = 0V	T	F
Gate	Gate Sense Input – Clutch or Side Stand Input	Gate Sense Input – Clutch or Side Stand Input	True – On = +12 False – On = 0V	F	F
On	Power On Input from Ignition – Turn Unit On	Power Input from Ignition – Turn Unit On	High + 12V on	T	T

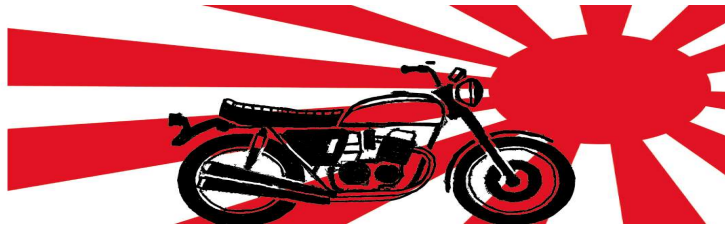

OUTPUTS

The output functions are listed below and are reasonably obvious – All Outputs drive +12V out when on through 30A rated MOSFETS, and are protected by one of the two main 10A fuses -

The power circuits are arranged so that the ignition, grips, horn are on one circuit, and the lights on the other to spread the load evenly.

Output Functions

Output	Function	Polarity	Power Circuit
HB	H igh B eam Power Out	+12V ON	B
TAIL	T ail L ight Power Out	+12V ON	A
LB	L ow B eam Power Out	+12V ON	B
BRK	B rake L ight Power Out	+12V ON	A
LEFT	L eft I ndicator Power Out	+12V ON	B
IGN	I gnition Power Out	+12V ON	A
RIGHT	R ight I ndicator Power Out	+12V ON	B
HORN	H orn Power Out	+12V ON	A
START	S tarter R elay Power Out	+12V ON	B
GRIP	Heated G rip Power Out / Power On output	+12V ON	A

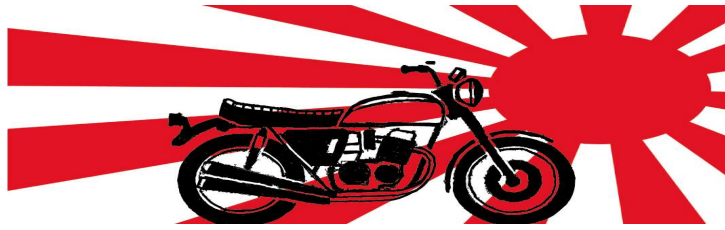

4 BUTTON MODE

When using the 4-button mode – there are several standard mappings of the button presses to functions that are detailed in the table below.

Map 1 has been designed to make the important safety functions – kill and horn quickly accessible on the upper buttons – similar to where they would normally reside. This is a good layout to start with

Other maps are variations – and can easily be customized within the code – or if you have a way you want it to operate can be incorporated.

Press Type	Timing
Double press	Two press within 0.8s, both longer than 0.06s
Short Press	Single press more than 0.3s less than 1.0s
Medium Press	Single press more than 1.0s less than 3.5s
Long Press	Single press more than 3.5s less than 10.0s

Note that the starter and horn can be timed or toggle functions depending on the map chosen. Horn Timeout = 2s, Starter Timeout = 3s

Also available in 4 Button mode is Indicate to merge – this will flash the indicator for 4.0 s to indicate a lane change, rather than the longer timed flash value – or infinite till toggled off flash.

Input	Button press	Map 1	Map 2	Map 3	Map 4
Horn Time	-	Toggled	Toggled	Toggled	Toggled
Starter Time	-	Toggled	Timed	Toggled	Timed
Left UP	Double press	Horn	-	-	-
	Short press	High / Low Beam	High / Low Beam	Horn	High / Low Beam
	Medium press	-	Modulation Toggle	High / Low Beam	Modulation Toggle
	Long press	Modulation Toggle	-	-	-
Left DOWN	Double press	Left Merge	-	-	-
	Short press	Left Indicator	Horn	Left Indicator	Horn
	Medium press	Heat Grip Toggle	Left Indicator	Heater Up	Left Indicator
	Long press	-	-	Heat Grip Toggle	-

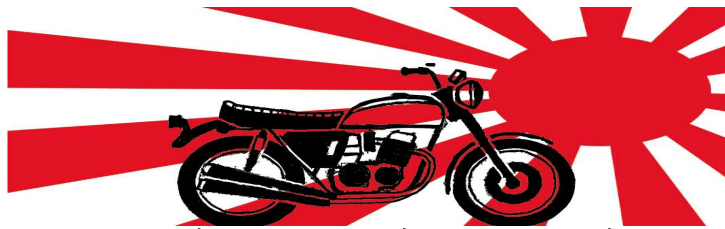

Right UP	Double press	Kill Toggle		-	-
	Short press	Heater Up	Heater Up	Starter	Heater Up
	Medium press	Lights Toggle	Heat Grip Toggle	Kill Toggle	Heat Grip Toggle
	Long press	Heat Grip Toggle	Lights Toggle	-	Lights Toggle
Right DOWN	Double press	Right Merge	-	-	-
	Short press	Right Indicator	Kill Toggle	Right Indicator	Kill Toggle
	Medium press	Starter	Right Indicator	Lights Toggle	Right Indicator
	Long press	-	Starter	Modulation Toggle	Starter

Heated Grip Function

The Heated Grips function provides drive to heated grips using the stock controls – so you don't need to add any extra buttons.

The Heating can be turned on and off and adjusted in level with the number of heat steps being configurable. The system remembers the last heat setting and returns to it when turned on.

The Heated grip output is a PWM so could be used to drive some other variable function if required.

The heated grip duty cycle takes into account the power relationship to voltage and is calculated to give equal heating steps.

If disabled in the configuration menu – the Heated grip function will be inoperative, and the output will be powered on at all times when the ignition is switched on to provide an always on power source. This can be used to power instruments or other devices.

Using the normal controls the heated grip function uses the starter button –

- when the Gated input is active to allow starting – i.e., in Neutral or the clutch is pulled in then the Starter button will work as the starter button.
- If however the Gate input is not active – i.e. normal running mode, clutch out and not in Neutral – then pressing the starter button will be interpreted as a Heated Grip control command
- The Heat setting increases one step on each press and cycles around to minimum from maximum.

Function	Normal Mode	4 Button Mode
Toggle Heated Grips ON / Off	Starter Button Long Press > 3.5s < 10s with Gate Inactive	Medium or Long Press of Right Up – see 4 Button Mode table

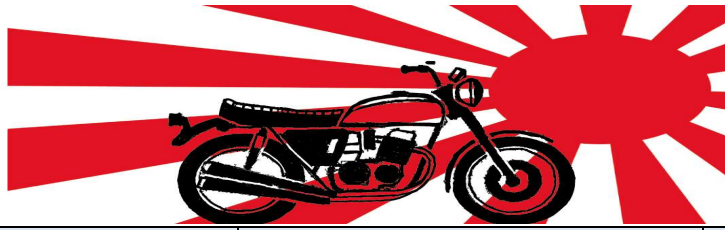

Increase Heat One Step – Cycles around	Starter Button press short press > 0.3s < 1.0s with Gate inactive	Short press Right Up – see 4 Button Mode table
--	---	--

Headlight Modulation Function

The Headlight Modulation function allows for the rapid variation of the low beam headlight to increase the likelihood of being seen by other road users.

It varies with country as to whether it is legal to be operated during the hours of darkness – but is generally fine to be used during daylight hours.

The Headlight intensity is varied at the allowed rate of around 5Hz, and the amount of modulation can be set. It is always a max intensity of 100% and the minimum can be set from 80 down to 0%. This is needed as in particular some LED headlights will attempt to compensate and fight against the voltage modulation- these generally need the modulation depth set to go down closer to zero.

If disabled in the configuration menu – the Headlight Modulation function will be inoperative.

Function	Normal Mode	4 Button Mode
Toggle Headlight Modulation ON / Off	Set To Low Beam and Switch to High for Press > 0.1s < 0.5s (ie quick flick to high beam and back)	Medium or Long Press of Left Up – see 4 Button Mode table

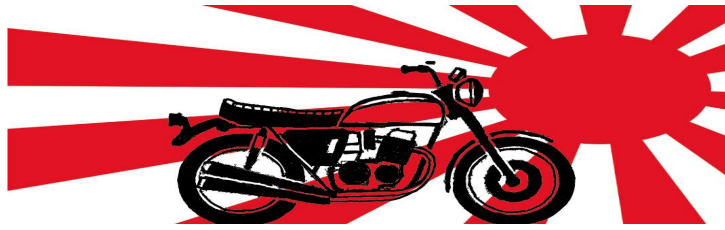

CONFIGURATION

The configuration menu is available by serial interface over the USB connection – simply plug in and use your favorite terminal program that supports ANSI sequences - Putty is generally the easy choice, being universally available and free.

Connect at 115200, 8, N,1 (115200 baud, 8bits, no parity, 1 stop bit) as a terminal

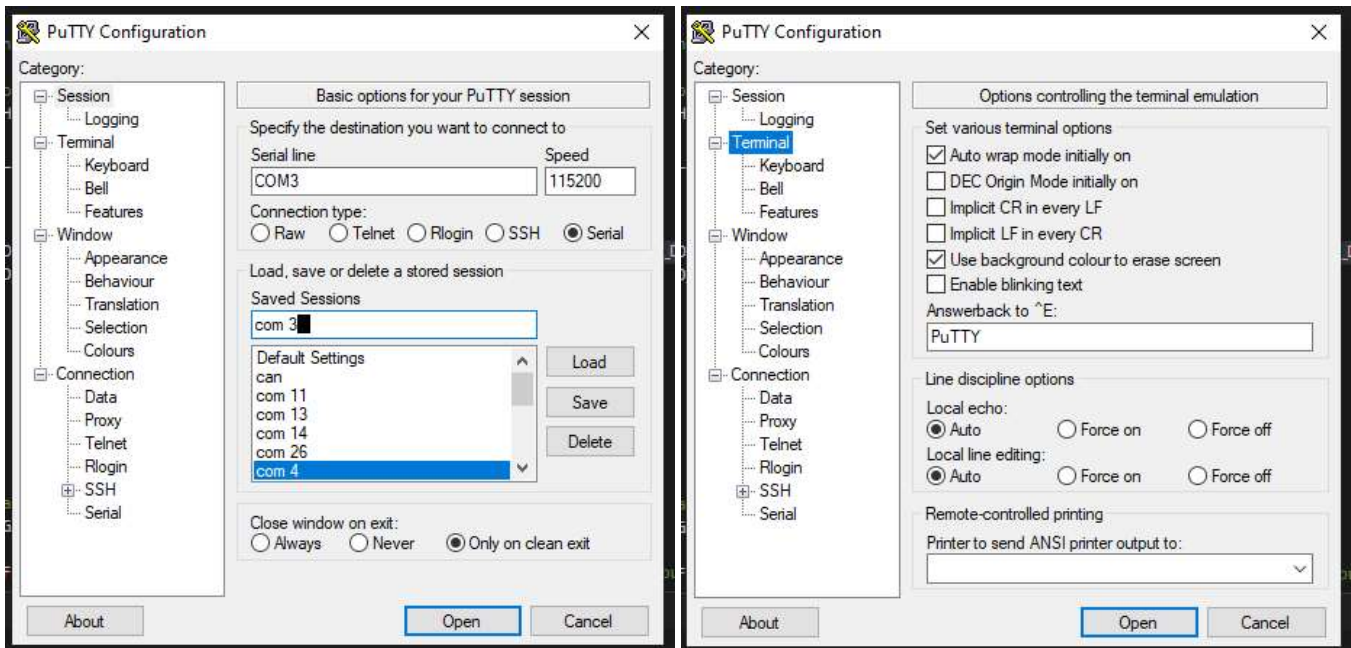

Once connected hit the R key to refresh and you should get the following screen

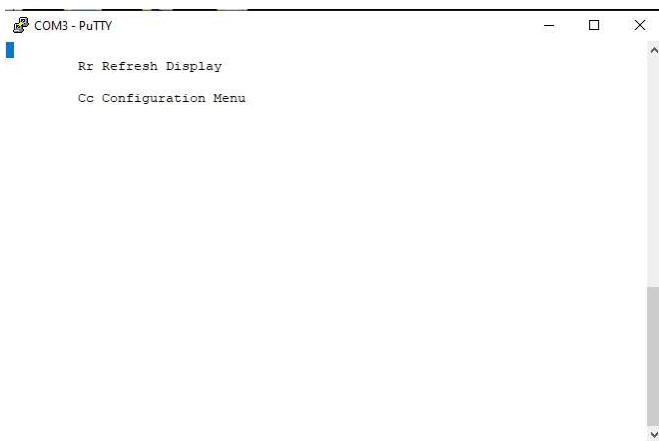

From here – push the C or c to enter the configuration menu.

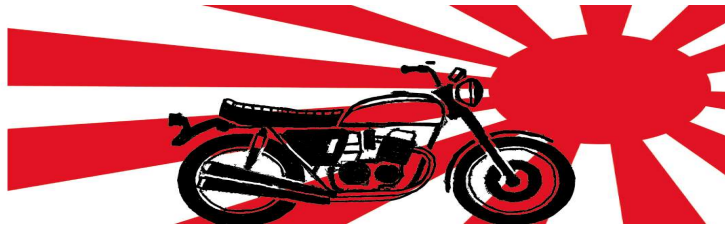

You will be presented with the left screen below – not the key explanation on the screen – repeated here in table form

Keystroke	Function
E or e	Enter Edit mode – selected entry will turn RED
N or n	Next – move to the next editable entry
P or p	Previous – move to the previous editable entry
> or .	Change selected Value Up
< or ,	Change selected Value Down
R or r	Refresh / redraw the screen
S or s	Saves the current set of values and exist edit mode
Q or q	Exit edit mode without saving changes and returns to the top level menu

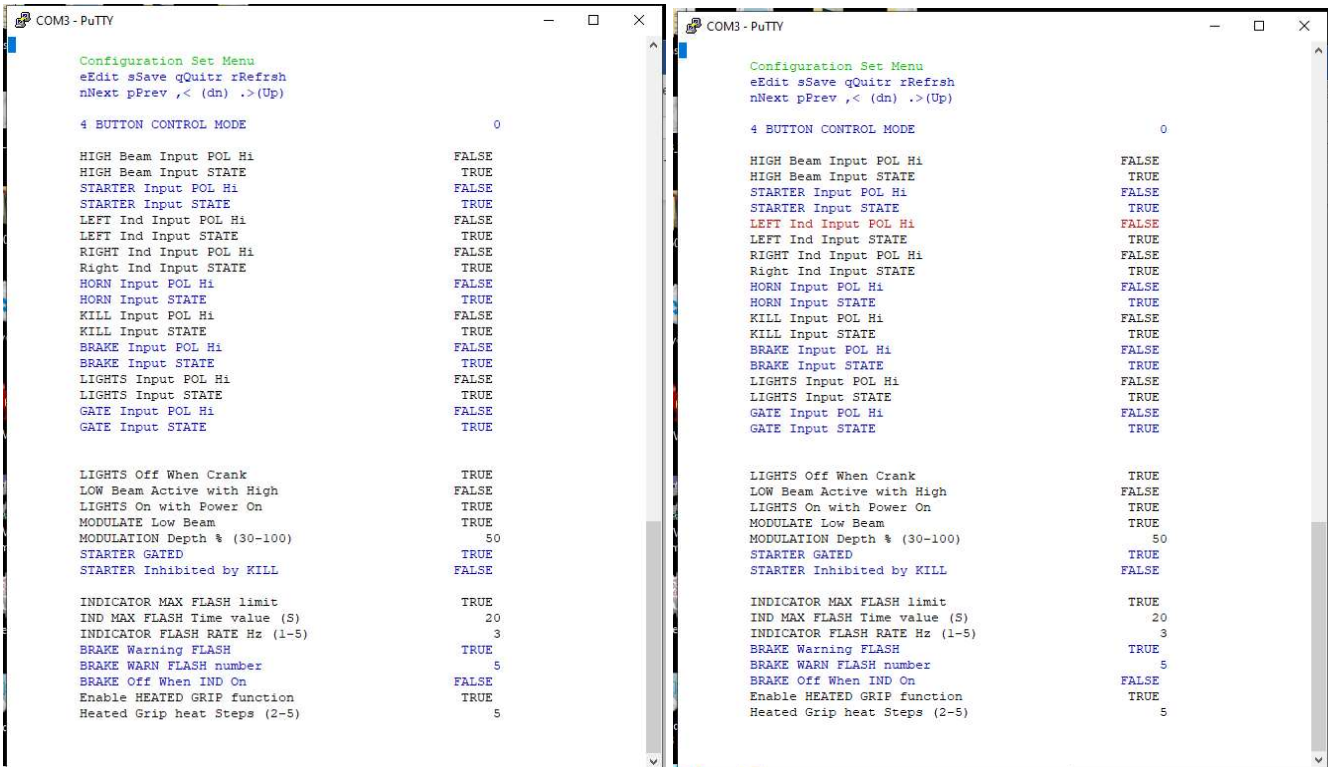

You can move around the values and change those you need to change – and then save or quit. Values are explained in the table following.

Default values as shipped are shown **BOLDED**.



Value	Function / affects / explanation	Normal polarity setting	Diagram Custom	4 button mode setting
4 BUTTON CONTROL MODE	0 => Normal all input mode 1..4 => use 4 Button map 1..4	0	<u>0</u>	1..4
HIGH Beam Input POL Hi	TRUE => Active on = +12V FALSE=> Active on = 0V	TRUE	<u>FALSE</u>	FALSE
HIGH Beam Input STATE	TRUE => On while Held FALSE=> Press is Latched	TRUE	<u>TRUE</u>	FALSE
STARTER Input POL Hi	TRUE => Active on = +12V FALSE=> Active on = 0V	TRUE	<u>FALSE</u>	FALSE
STARTER Input STATE	TRUE => On while Held FALSE=> Press is Latched	TRUE	<u>TRUE</u>	FALSE
LEFT Ind Input POL Hi	TRUE => Active on = +12V FALSE=> Active on = 0V	TRUE	<u>FALSE</u>	FALSE
LEFT Ind Input STATE	TRUE => On while Held FALSE=> Press is Latched	TRUE	<u>TRUE</u>	FALSE
RIGHT Ind Input POL Hi	TRUE => Active on = +12V FALSE=> Active on = 0V	TRUE	<u>FALSE</u>	FALSE
RIGHT Ind Input STATE	TRUE => On while Held FALSE=> Press is Latched	TRUE	<u>TRUE</u>	FALSE
HORN Input POL Hi	TRUE => Active on = +12V FALSE=> Active on = 0V	TRUE	<u>FALSE</u>	FALSE
HORN Input STATE	TRUE => On while Held FALSE=> Press is Latched	TRUE	<u>TRUE</u>	FALSE
KILL Input POL Hi	TRUE => Active on = +12V FALSE=> Active on = 0V	FALSE	<u>FALSE</u>	FALSE
KILL Input STATE	TRUE => On while Held FALSE=> Press is Latched	TRUE	<u>TRUE</u>	FALSE
BRAKE Input POL Hi	TRUE => Active on = +12V FALSE=> Active on = 0V	TRUE	<u>FALSE</u>	FALSE
BRAKE Input STATE	TRUE => On while Held FALSE=> Press is Latched	TRUE	<u>TRUE</u>	TRUE
LIGHTS Input POL Hi	TRUE => Active on = +12V FALSE=> Active on = 0V	TRUE	<u>FALSE</u>	FALSE
LIGHTS Input STATE	TRUE => On while Held FALSE=> Press is Latched	TRUE	<u>TRUE</u>	FALSE
GATE Input POL Hi	TRUE => Active on = +12V FALSE=> Active on = 0V	FALSE	<u>FALSE</u>	FALSE
GATE Input STATE	TRUE => On while Held FALSE=> Press is Latched	TRUE	<u>TRUE</u>	TRUE
LIGHTS Off When Crank	Turn Headlights off while cranking NOTE THAT LIGHTS ON WITH POWER OVERRIDES THIS	TRUE	<u>TRUE</u>	TRUE
LOW Beam Active with High	Leave Low Beam On when High On	FALSE	<u>FALSE</u>	FALSE
LIGHTS On With Power On	Turn Low and Tail on when powered – ignore Lights input	TRUE	<u>TRUE</u>	TRUE
MODULATE Low Beam	Enable the Modulation Function	TRUE	<u>TRUE</u>	TRUE
MODULATION Depth % (30=100)	Set how Dim the Modulation goes	50	<u>50</u>	50

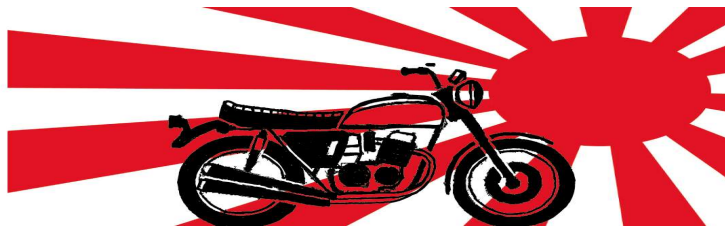

STARTER Inhibited	TRUE => starter can be inhibited by kill or gate – FALSE => Starter always available ignore gate and kill inputs for starter	TRUE	<u>TRUE</u>	FALSE
STARTER Gated	TRUE=> Gate must be active to start FALSE=> Ignore Gate Input	TRUE	<u>FALSE</u>	TRUE
STARTER Inhibited by Kill	TRUE => Starter wont activate if Kill Active FALSE => Starter ignores Kill Switch setting	FALSE	<u>FALSE</u>	FALSE
INDICATOR MAX FLASH Limit	TRUE => Count Flashes for time then stop FALSE => Flash forever until button deactivated	TRUE	<u>TRUE</u>	TRUE
IND MAX FLASH Time Value	Time Limit in Seconds for Flashing (10 – 90)	20	<u>20</u>	20
INDICATOR FLASH RATE Hz (1-5)	Number Of Flashes per Second – nominal 3Hz	3	<u>3</u>	3
BRAKE Warning FLASH	TRUE=> Fast Flash Brake Light when first activated to grab attention FALSE=>Standard Brake Light	TRUE	<u>TRUE</u>	TRUE
BRAKE WARN FLASH Number	If Warning Flash ON – Number of Flashes (0 – 10)	5	<u>5</u>	5
BRAKE Off when IND On	TRUE=> Brake Light turned off when indicator flashes – used to make integrated indicator / brakes lights more visible FALSE=> Brake Light on, Indicator Flash Normal – doesn't affect brake light.	FALSE	<u>FALSE</u>	FALSE
Enable HEATED GRIP Function	TRUE=> Enables the PWM headed grip function- FALSE=> No Heated Grip Function Active – Power On output	FALSE	<u>TRUE</u>	FALSE
Heated Grip Heat Steps (2-5)	Number of graduations in the heated grips settings. These are equally heat spaced (2-5)	4	<u>5</u>	4

Custom control Setup – Easiest approach

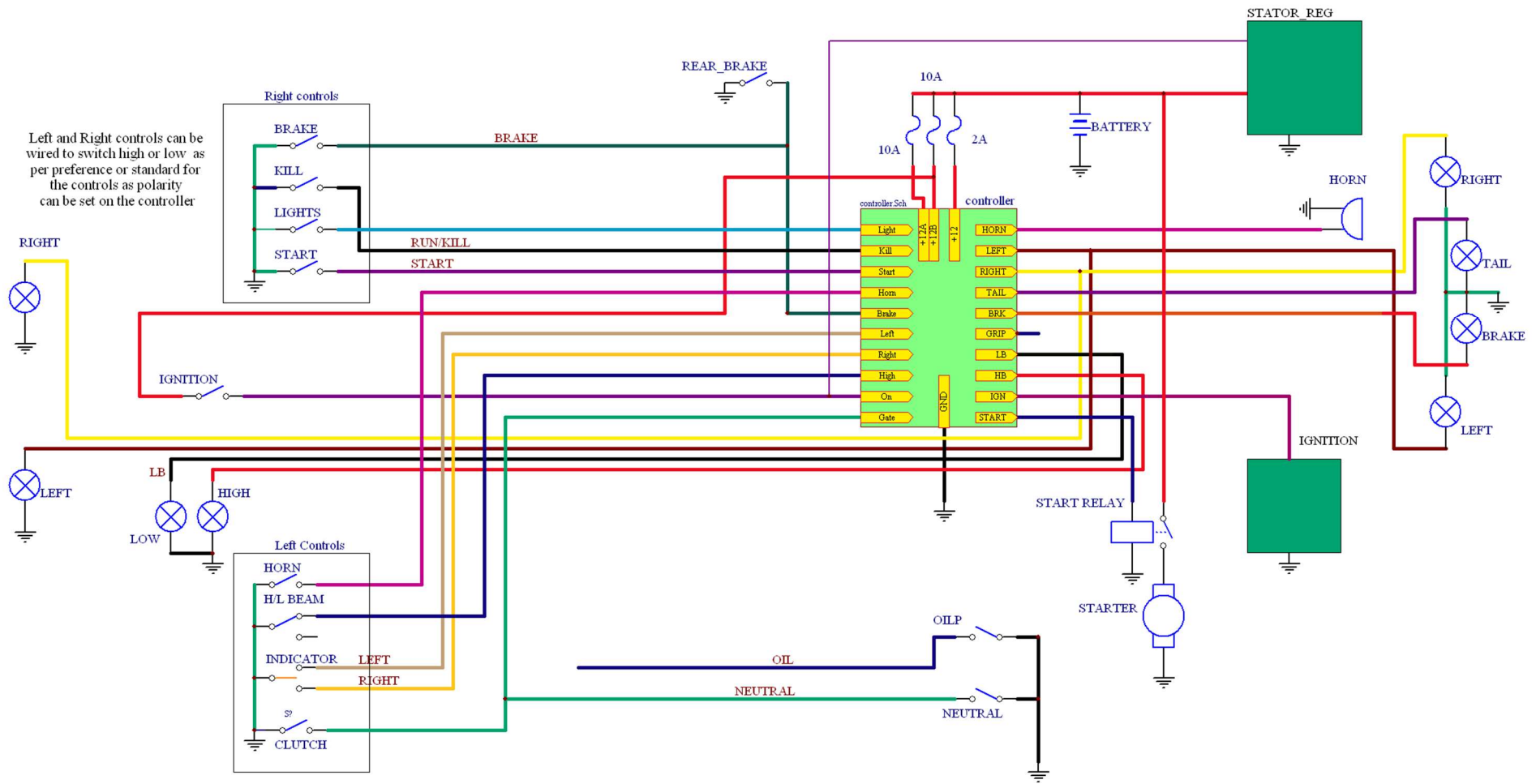

Standard Bike Control Setup

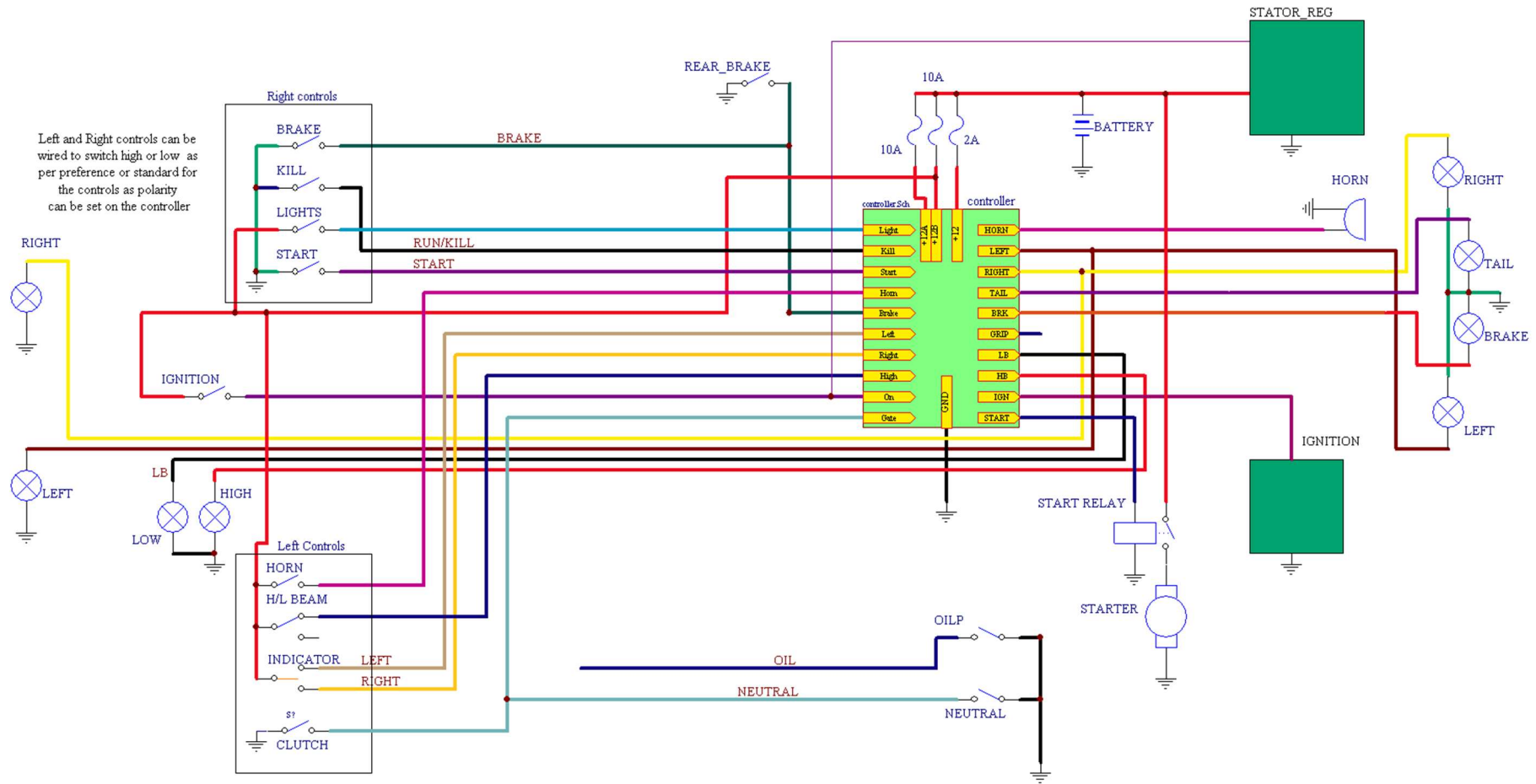

4 Button Setup – Active low

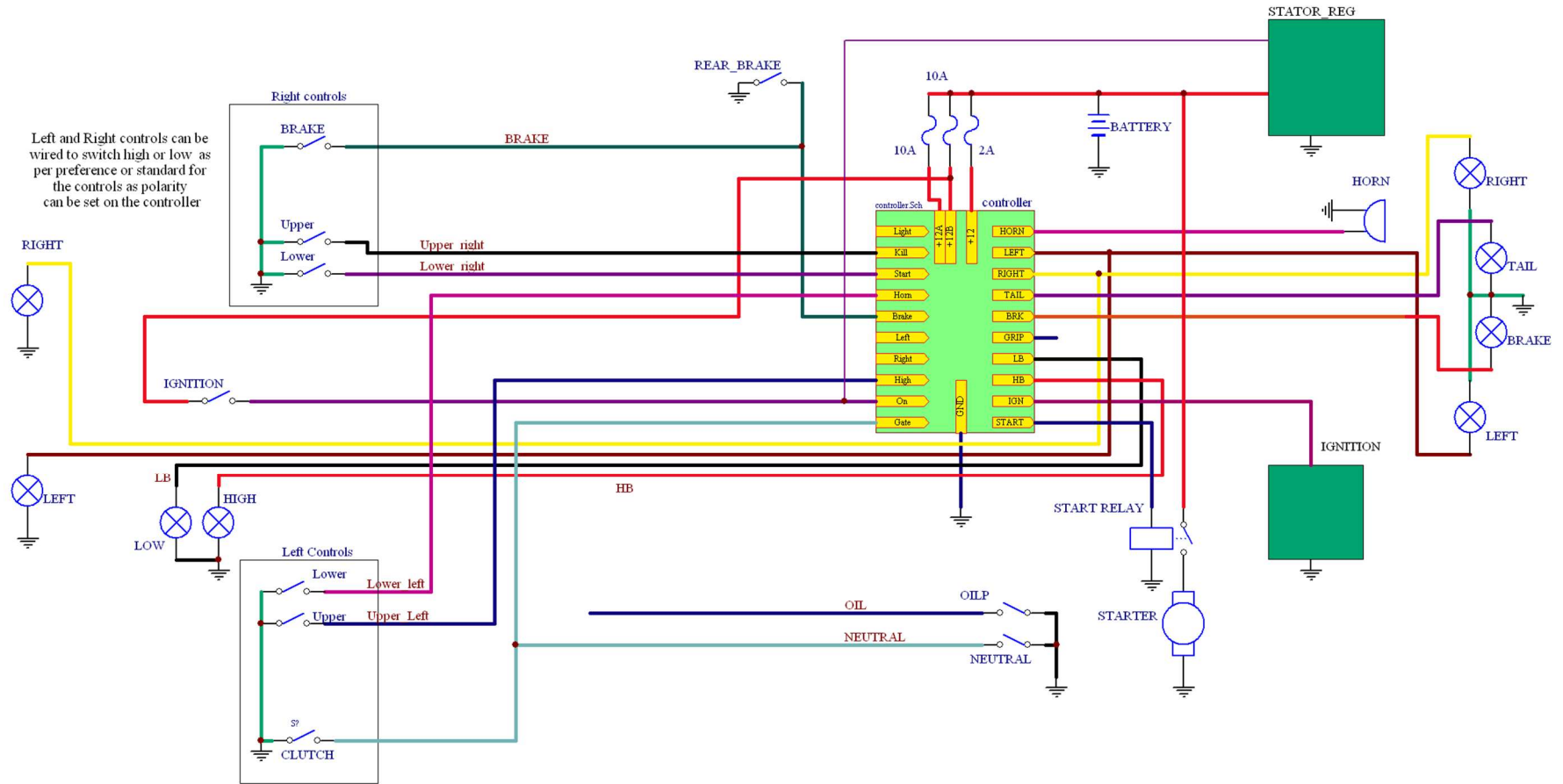

Using Stock Fuses

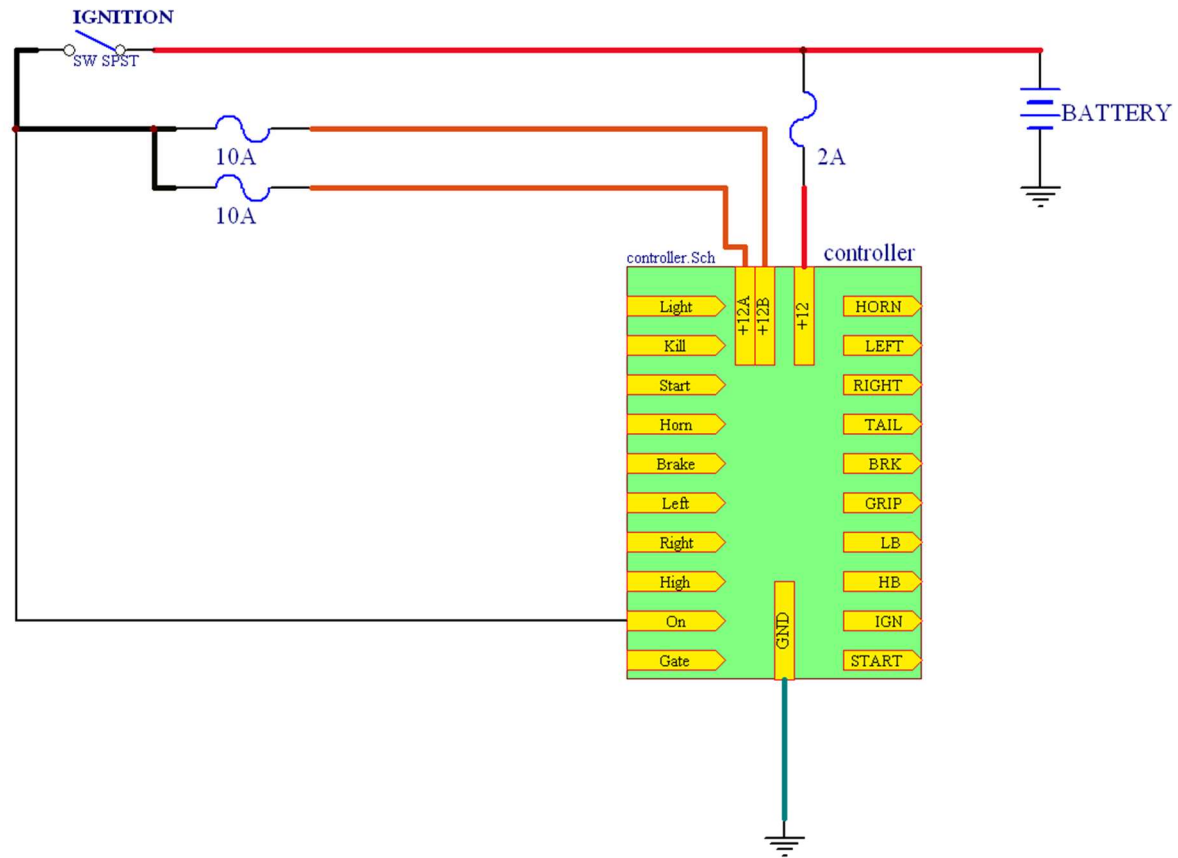

Adding Heated Grips

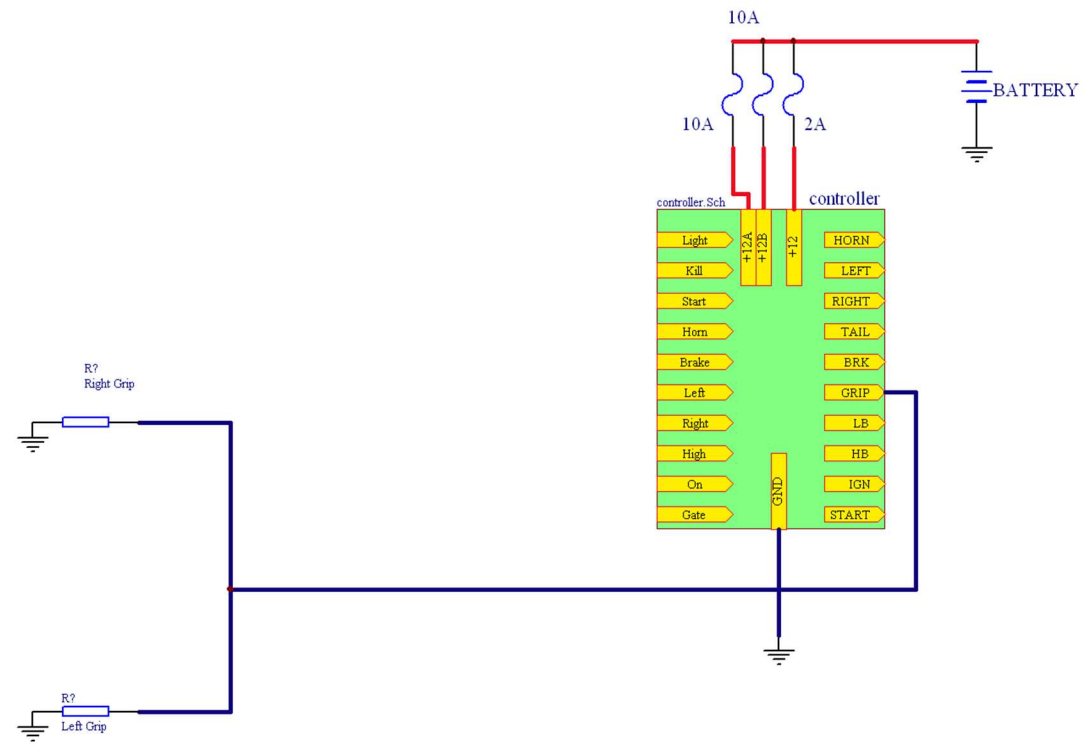

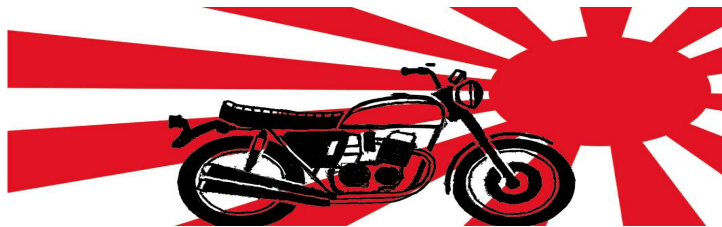

MOTORCYCLE PRODUCT DISCLAIMER

Motorcycling is an inherently dangerous activity, which may result in personal injury and / or death. While Rae-San (and/or Entities Trading as Rae-San) products are designed to offer superior riding comfort and performance, no product can offer complete protection from injury or damage to individuals and property in case of fall, loss of control or otherwise. You should wear appropriate protective equipment, obey all traffic laws, regulations and use good judgment. Never take alcohol or drugs (legal or illegal) before riding. Always inspect your motorcycle before riding, and read your owners manual. You should be familiar with the wide range of foreseeable hazards of motorcycling and decide whether to assume the risks inherent in such activity, which include damage to property, serious injury to you or others and death.

RAE-SAN (AND/OR ENTITIES TRADING AS RAE-SAN) DISCLAIMS ANY RESPONSIBILITY FOR INJURIES OR DAMAGES INCURRED WHILE USING ANY OF ITS PRODUCTS. RAE-SAN (AND/OR ENTITIES TRADING AS RAE-SAN) MAKES NO GUARANTEES OR REPRESENTATIONS, EXPRESSED OR IMPLIED, REGARDING MATERIALS AND WORKMANSHIP OR THE FITNESS OF ITS PRODUCTS FOR ANY PARTICULAR PURPOSE, FURTHER RAE-SAN (AND/OR ENTITIES TRADING AS RAE-SAN) MAKES NO GUARANTEES OR REPRESENTATIONS, EXPRESSED OR IMPLIED, REGARDING THE EXTENT TO WHICH ITS PRODUCTS PROTECT INDIVIDUALS OR PROPERTY FROM INJURY OR DEATH OR DAMAGE. RAE-SAN (AND/OR ENTITIES TRADING AS RAE-SAN) DISCLAIMS ANY RESPONSIBILITY FOR INJURIES, DEATH OR DAMAGES DUE TO IMPROPER INSTALLATION OF ITS PRODUCTS. ANY ACTUAL ATTORNEY FEES FOR ANY UNSUCCESSFUL CLAIM AGAINST SELLER TO BE PAID BY PLAINTIFF/COUNTER-CLAIMANT.

Modification of a motorcycle by fitting the devices obtained from Rae-San (and/or entities trading as Rae-San) may void manufacturer's warranty, state and federal laws and render insurance void. It is the responsibility of the motorcycle owner to be familiar with these laws. Fitting of any product from Rae-San (and/or entities trading as Rae-San) constitutes acceptance of the responsibility and consequences of any legal, insurance, or warranty breach by the motorcycle owner. Furthermore fitting of any device constitutes acceptance and agreement to indemnify Rae-San (and/or entities trading as Rae-San) of all damages and liabilities that may arise in the event of accident, misfortune or failure of a device.

12 MONTH LIMITED WARRANTY AND LIABILITY DISCLAIMER

Rae-San (and/or Entities Trading as Rae-San) warrants this product free from defects in material or workmanship for a period of 12 months from the date of purchase, except as noted. The product warranty does not cover damage caused by misuse or abuse; accident; the attachment of any unauthorized accessory; alteration to the product, improper installation, exposure to harsh weather and/or chemicals, lack of proper maintenance, lubrication, or any other conditions that are beyond the control of Rae-San (and/or Entities Trading as Rae-San). Rae-San (and/or Entities Trading as Rae-San) shall not be responsible for any type of incidental, consequential, or special damages. All

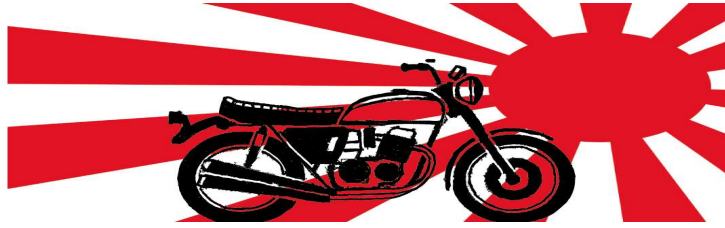

implied warranties, including but not limited to those warranties of fitness and merchant accountability, are limited in the total duration to 12 months from the original purchase date. If the warranty occurs within 30 days from the date of purchase, please contact the dealer the product was purchased from. Over 30 days from the date of purchase, please contact Rae-San (and/or Entities Trading as Rae-San) direct at Rae-San@Rae-San.com. Customer must contact Rae-San (and/or Entities Trading as Rae-San) prior to sending warranty product. Claims for lost shipment, damaged shipments, or other problems regarding freight must be made directly to the responsible carrier. Warranty is solely through Rae-San (and/or Entities Trading as Rae-San). Service to our products by anyone other than Rae-San (and/or Entities Trading as Rae-San) authorized installation centers voids warranty. Rae-San (and/or Entities Trading as Rae-San) disclaims any and all liability for consequential or incidental damages. Rae-San (and/or Entities Trading as Rae-San) will not be held responsible for personal damage, bodily harm or any other legal matters.