

V3.0 CDI Ignition Module

Installation Manual

Rae-San

31/3/2018

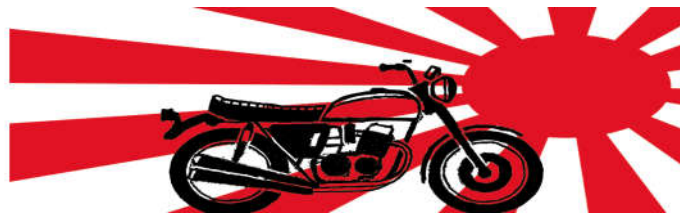

Rae-San Ignition Module V3.0 CDI

Congratulations on your purchase of a new ignition setup for your CX motorcycle.

Your Kit should be as depicted in one of the pictures below.

STOCK pickup SHORT Kit

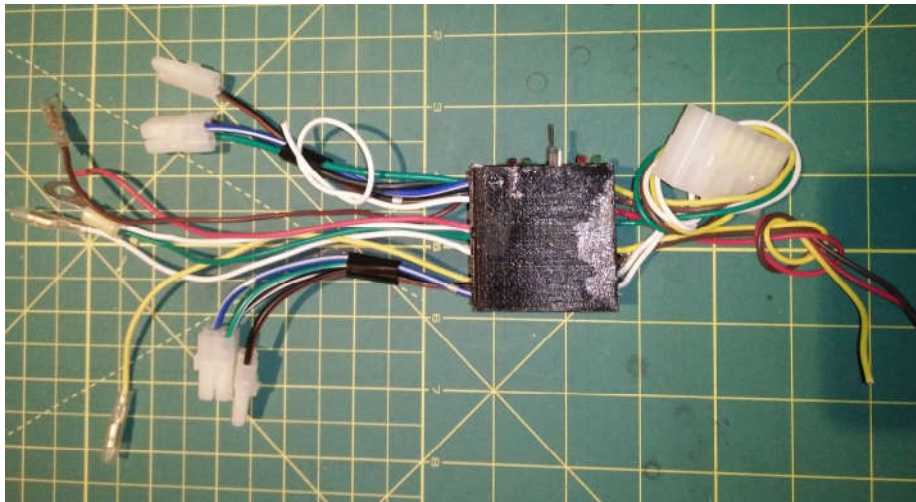

Or STOCK pickup FULL KIT

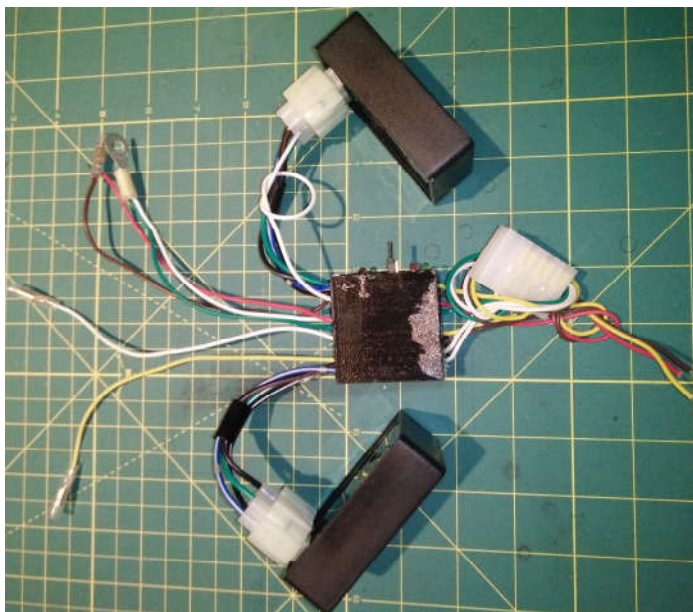

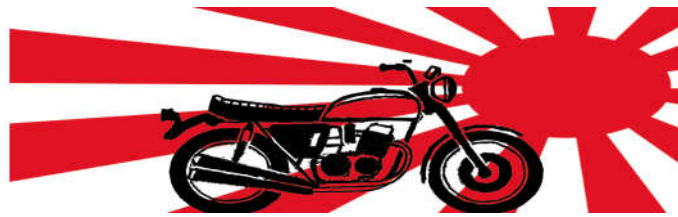

V3.0 HALL SHORT Kit

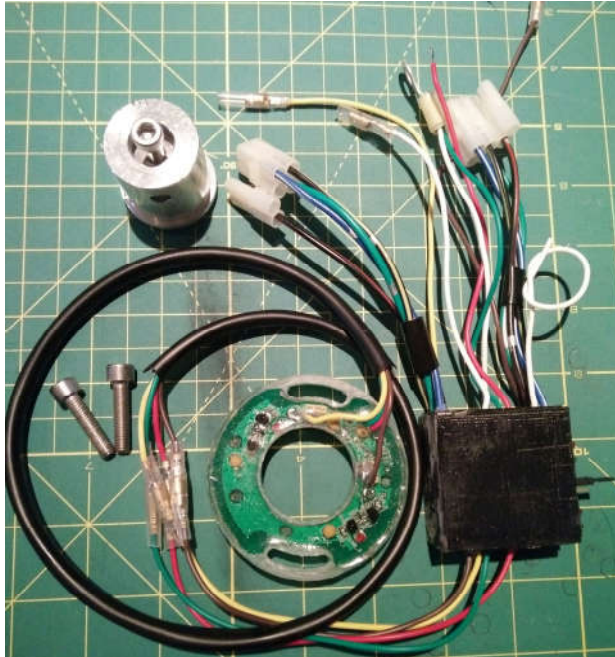

V3.0 HALL FULL Kit

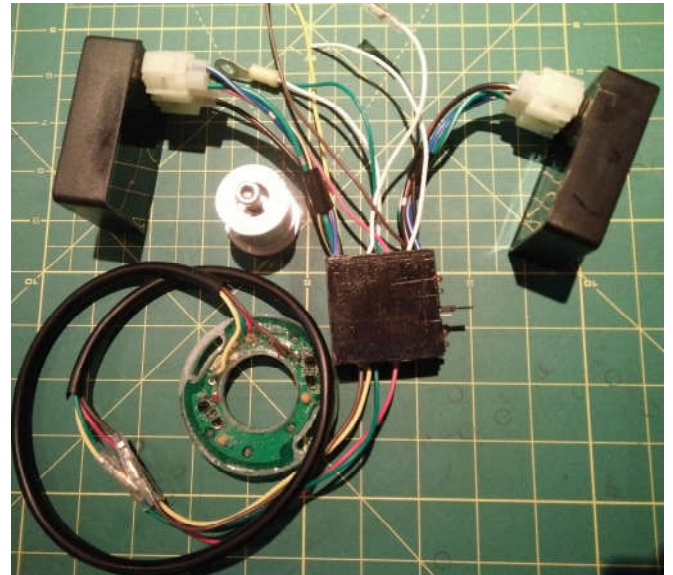

Note that the new revision has two indicator LEDs to indicate trigger pulses on the HALL sensor as well as Green and Red LEDs on the Advance Controller to indicate trigger and fire. A Tacho output option for driving electronic tachometers is now included.

The spark generation / CDI assembly is common to both setups – this uses commercially available GY6 –DC-CDI modules to create the high voltage and spark in to the CDI coils – these are used as they are quite readily available and inexpensive compared to most of the alternatives, or to a custom design.

These are supplied if a FULL Kit is ordered, or you will have purchased them separately if using the SHORT kit.



The Original System

This module is intended to provide you with a replacement to the original CDI system that was fitted from the factory. The factory fitted system uses two high voltage coils on the stator to generate approximately 100V AC which is rectified to 150 – 200V DC which is used to charge the capacitors in the CDI unit and which are then fired into the ignition coils. These High voltage generation coils are the most common source of electrical failure of on the CX 500. They contain about 4000 turns of smaller wire that is finer than fine hair.

Original Factory CDI unit





The above picture shows the stock CDI located in place and the connectors fitted –

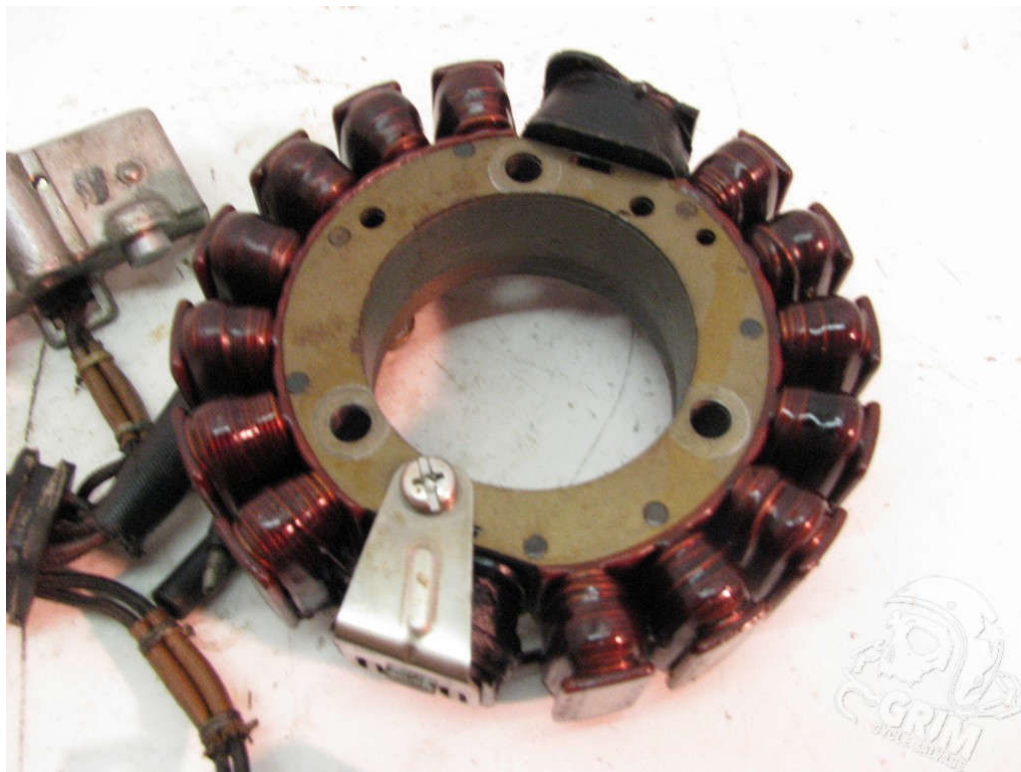

This picture shows a CX500 CDI stator – the two most commonly troublesome coils are the wider ones at the top and bottom of the picture, the bottom with a metal cover over it and the top has a bit of the cap chipped off. These coils contain approximately 4000 turns of very fine wire between them which is used to generate the high voltage required for the original CDI based ignition.

These coils deteriorate over time and use and eventually fail. In order to replace these two coils – the engine must be removed from the frame and the back cover removed to replace the whole stator even though the 12V generating coils are usually fine.

The diagram below shows the stator in situ on the rear cover with the pick-up coils in position and labelled – please note the sources of these images as indicated on the images themselves.

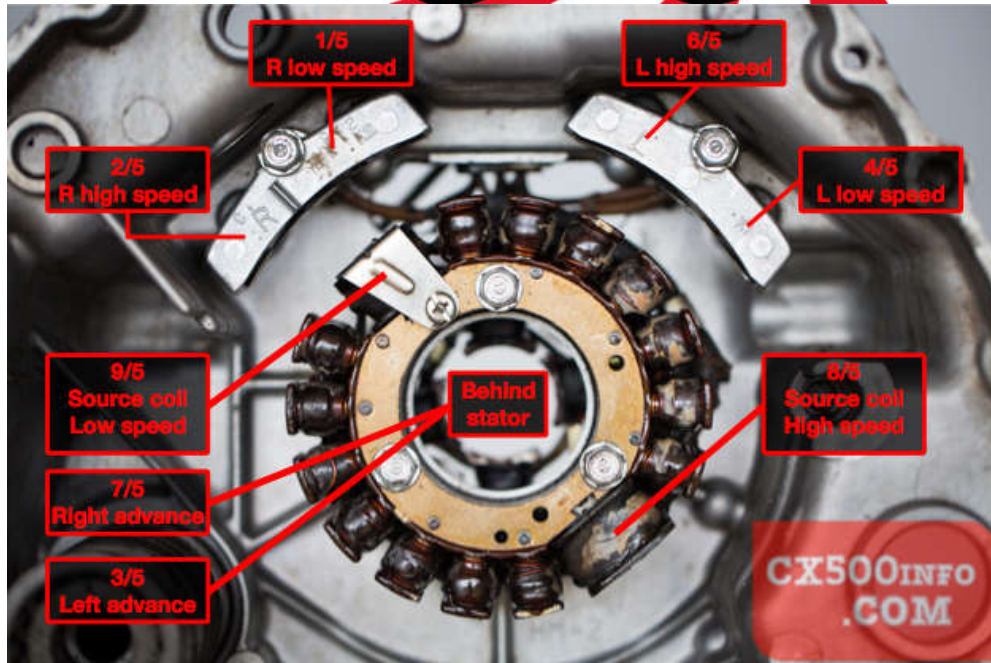

The Rae-San CX CDI ignition module allows you to use the stock trigger coils already present (the silver objects) and the 12V system of the bike to run the ignition without having to repair the failed CDI coils on the stator. This is referred to as the STOCK setup.

The Stock pickup coils as mentioned above are starting to also fail now – they are 30+ years old and consist of two sets of fine wire on a former, buried in a potting compound. They are no longer available as a part through Honda channels and they are becoming rare on the used market, as without them the CX engine is useless – Until now.

The Rae-San Hall Effect Ignition is used to replace these pickup coils with a hall-effect sensor and ignition advance controller that fits in the rear of the engine – where the original advance coils were positioned. This replaces the function of both pickup coils and the stator charging coils with new components, without the need to open the engine up.

Depending on your kit choice , your new Rae-San Ignition module:

uses the same trigger coils on the rear engine cover generate pulses which tell the microcomputer where the cranks is and when it is time to fire the spark. – This is the **STOCK COIL** setup

or

uses a **HALL EFFECT** sensor to generate the timing pulses that pulses which tell the microcomputer where the cranks is and when it is time to fire the spark.

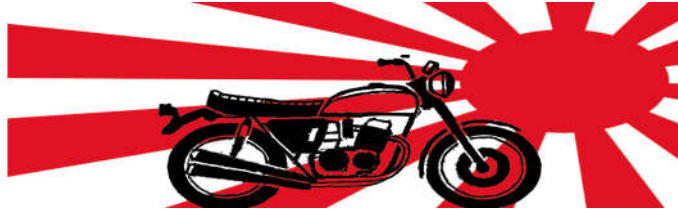

All Rae-San versions provide features of:

- Operates of 12V only – works if the Stator High Voltage windings are dead
- Provides electronically adjusted advance.
- Provides ability to choose from 4 standard advance profiles.
- Contains two completely independent circuits – one for each cylinder to provide failsafe redundancy.
- Provides Higher spark energy than original.
- Provides Tacho Output Signal for driving Electronic Tachometers.
- Existing CDI kill switch functionality is retained so there is no need to rewire switches.

Modifications Required

The existing CDI box is removed - and the new Rae-San ignition unit put in its place. Power wiring is necessary to provide 12V to the new system.

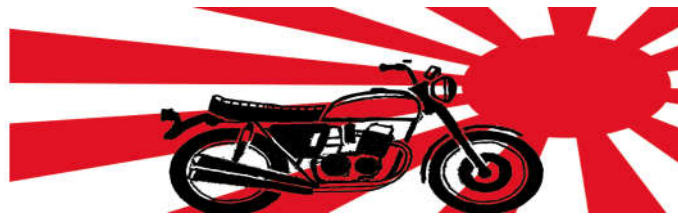

Installation – Hall Effect Sensor

The process is easiest if starting with the engine out of the bike. It is possible to do the install in the bike with a lot of fiddling and removal of the water bottle – or swinging the engine down at the rear maybe – but I'll show the process with the engine removed as this allows for easy access and photography.

It's recommended that a dry run of the installation be performed first – without thread-locker or epoxies, so you can get a feel for the adjustment and see how the alignment stacks up.

Once you've done the dry run it will only take a few minutes to perform the final installation.

Lets begin:

The photo below shows the rear of the engine, ready for the installation. To get to this stage :

- Remove the engine from the bike – see the service manual if you need to
- Remove the ignition advance cover plate
- Remove the Advance sensor coils – unplug the two bullet connectors and then the two Philips head screws – pull out the assembly.
- Remove the bolt in the centre of the rotor and remove the rotor –
- Sell the Removed rotor and advance pickup on ebay ;)



The next picture shows the crank access needed to be able to set the timing

- Unscrew the 17mm bolt on the access cover on the front of the engine
- Attach a 17mm ratchet or similar to the front of the crank.
- Unscrew the timing access port on the side of the engine – depending on the year of manufacture this may be just a cover the same as the front or may be a breather arrangement.



The next step is to install the rotor onto the rear of the crankshaft.

First set the timing to the FL mark.



For the Rotor with Tang :



- If there is not already a line marked on the top of the rotor – in line with the trailing edge of the magnet – then it will make things easier if one is marked now – just use a felt tip marker.
- Place the rotor on the rear of the crank with the tang in the slot – It will only fit in one position.
- Put a small amount of thread-locker on the bolt and screw into place with a washer fitted.
- Do up snug with an hex key/ socket as appropriate.

Note - the rotor has two positions where the magnet can be fitted into it – only one will be filled – this is correct and normal – the other position is for an alternate arrangement not relevant here.



Below shows another angle of the magnet.

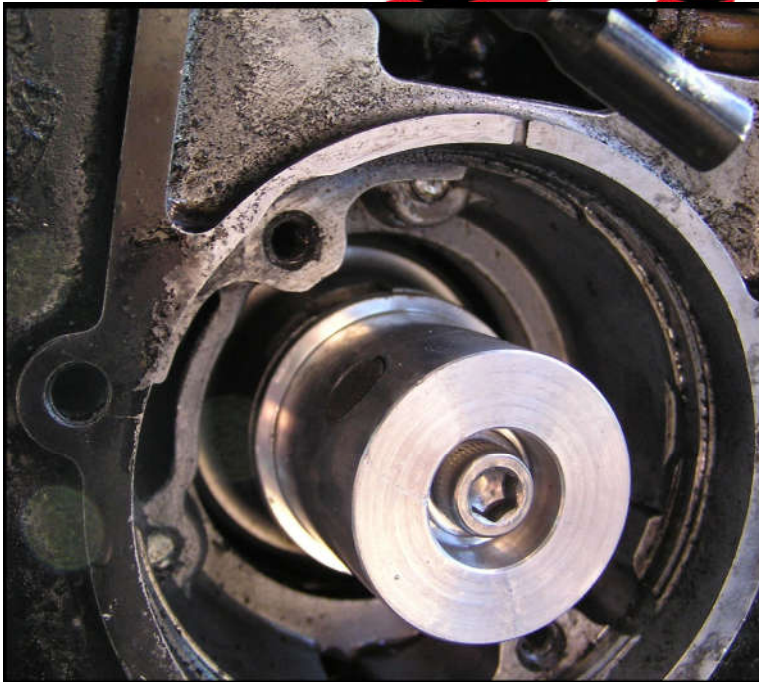
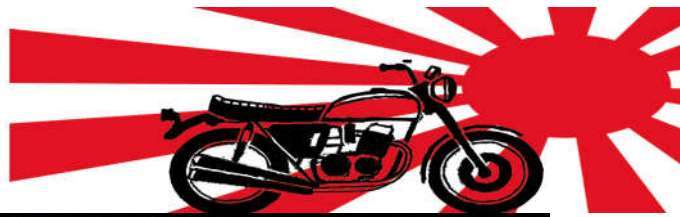

The next step is to put the hall pickup and advancer circuitry in place -

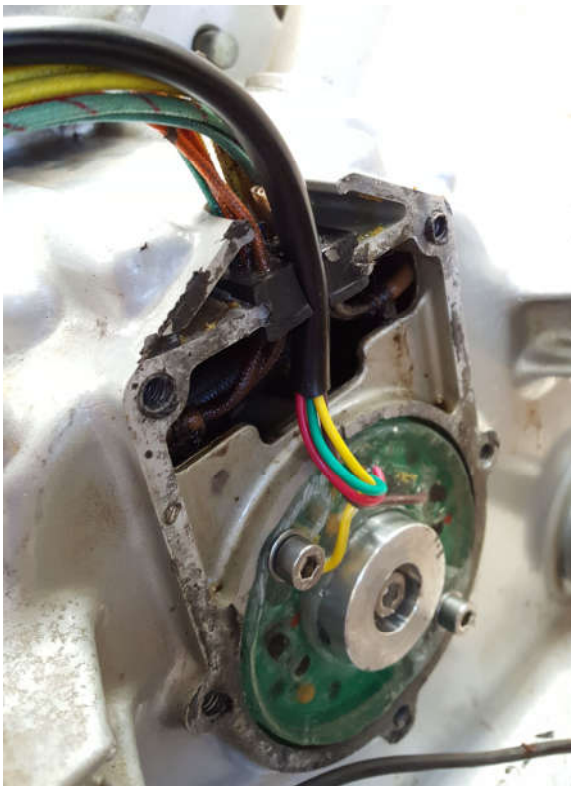



The rotor is in a fixed location so it is necessary to rotate the Hall Advancer circuit to achieve the required timing result.

- Mount the board as shown below
- Put some thread-locker on the screws before doing the two M5 screws up – only gently at this stage –
- Note the orientation – the power wires should be close to the centre top.
- The trailing edge of the magnet in the rotor – should line up with the hall effect pickup – You can see the two black lines aligned in the photo above.

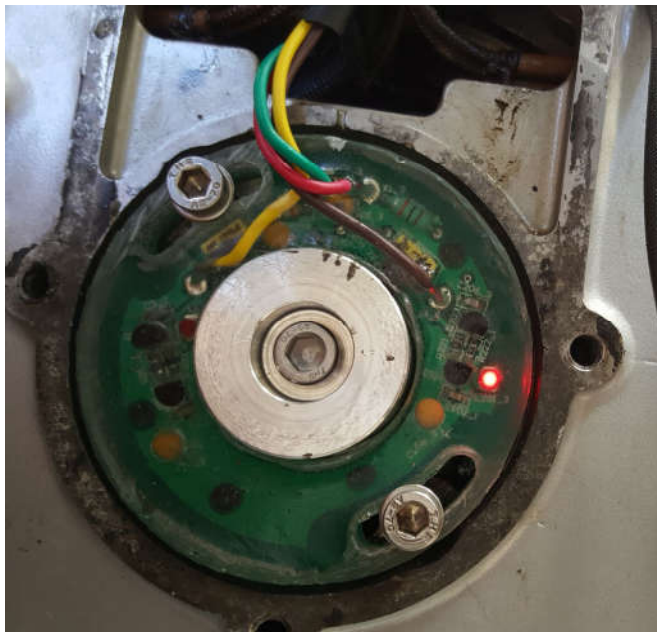

Now it is time to apply power to the Hall Advancer so we can observe the LEDS and set the timing up

- If the CDI driver module has already been installed then the Hall Advancer can be connected to this for power – **RECOMMENDED APPROACH**
- If the bikes battery is available then connection can be made to it
- If not an external battery can be used as shown below
- **RED –is POSITIVE**
- **GREEN is NEGATIVE/GROUND**
- **TRIPLE CHECK THE POLARITY**

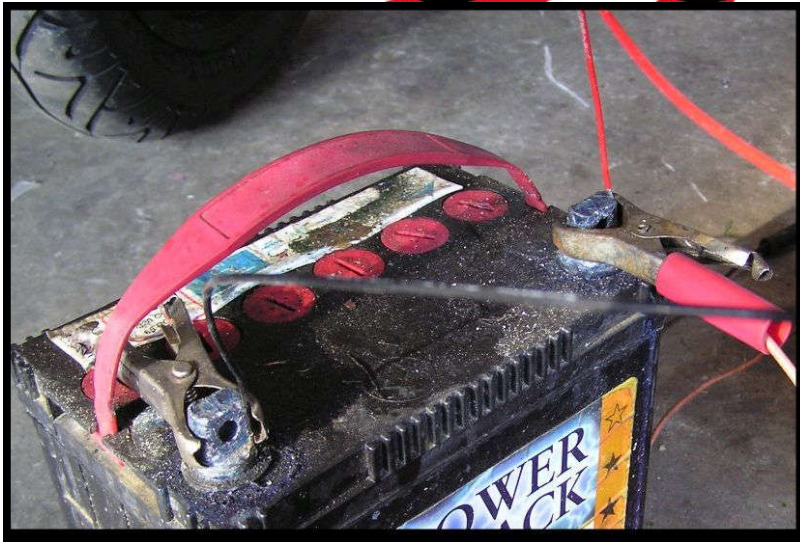
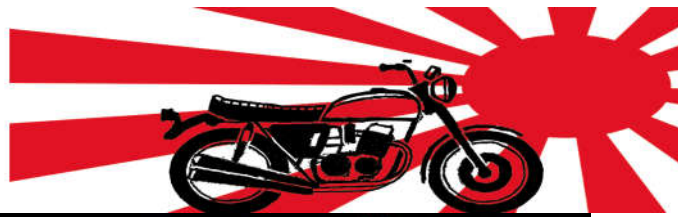

Once again – RED = +ve GREEN = -ve
Don't get it wrong or the unit will be damaged.

As a final check before setting the timing – check that the rotor and the Hall Advancer are centred with consist end gaps all the way around – the rotor should rotate without touching anything.

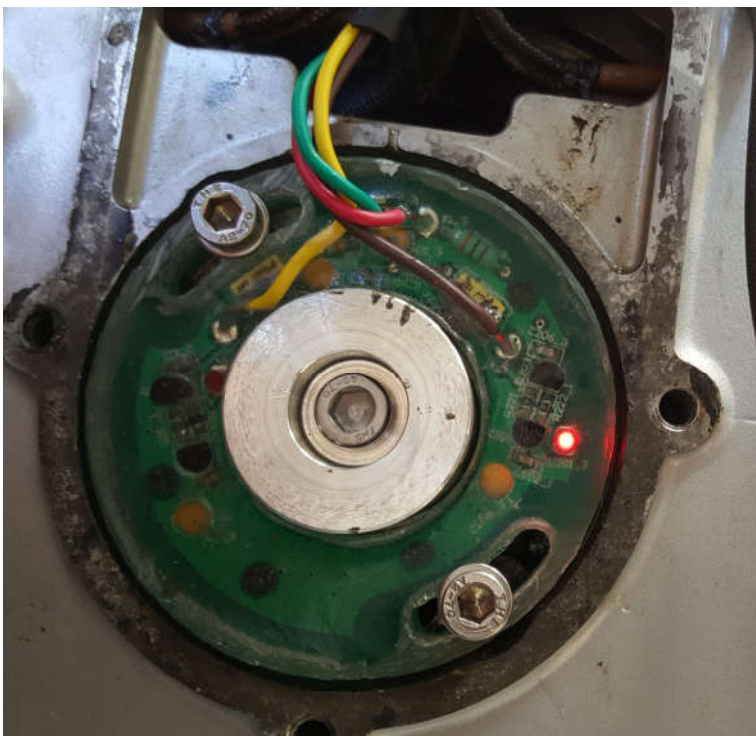



There are two LEDs on the Hall Advancer – ONE for each side –Red LED Left and RED Led Right.

- **RED LED** – This lights to show when the magnet is detected by the Hall effect pickup – so the aim is that this led should be ON between the full advance and the FR/FL marks – It should turn off as close as possible to the FR mark for the RIGHT side and as close as possible to the FL mark for the LEFT side.
- **NOTE THAT IF USING THE CDI DIRVER / ADVANCE CONTROLLER the GREEN LED on this will mirror the RED LED on the HALL SENSOR.**

Set the Timing

Lets start with the Right Cylinder.

- Set the crank to the FR position as shown in the photo below.



- Loosen the M5 bolt(s) to adjust the timing –
- By moving the Hall Assembly back and forth slightly – set the position so that the RED Led for the RIGHT side turns OFF as near as possible the current position.
- The picture below show the RIGHT RED Led on, and the magnet passing the Hall pickup (small black dot near the magnet on the rotor)
- Tighten the bolt(s) slightly – just enough to hold.



Next set the crank to the FL position – as shown below.

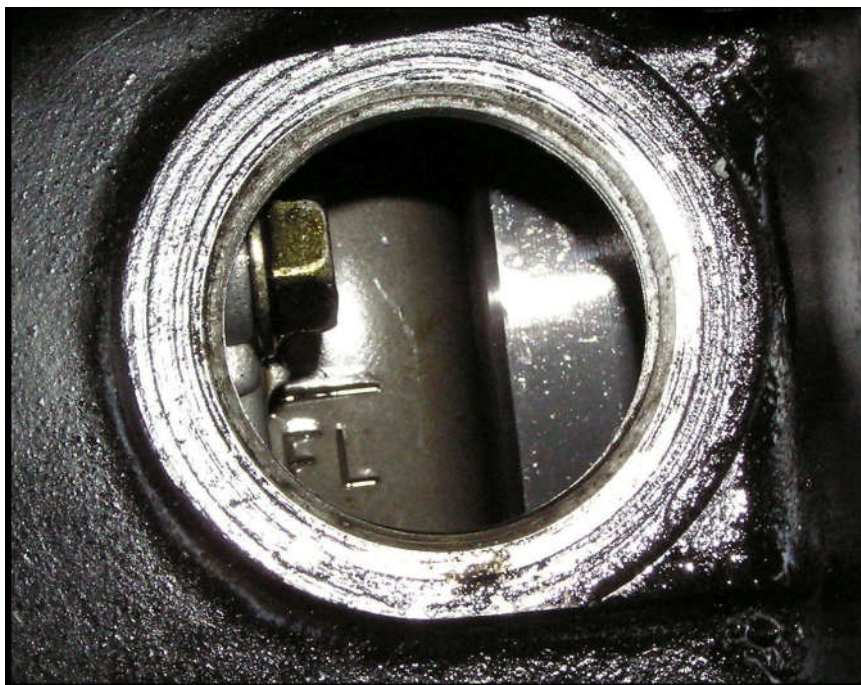

- Loosen the M5 bolt(s) to adjust the timing –



- By moving the rotor or Hall Assembly back and forth slightly – set the position so that the RED Led for the LEFT side turns OFF as near as possible the current position -.
- The picture below show the LEFT REDLed on, and the magnet passing the Hall pickup (small black dot near the magnet on the rotor)
- Aim to have any errors shared equally around the FR and FL marks – Usually RIGHT side will need to extinguish slightly before the FR mark and the LEFT Side extinguish slightly after the FL mark, due to the polarity of the flywheel magnets, which distort the magnetic fields around the rotor slightly.
- LEFT RED led is shown on below – and the magnet can be seen on the Left Hall pickup.

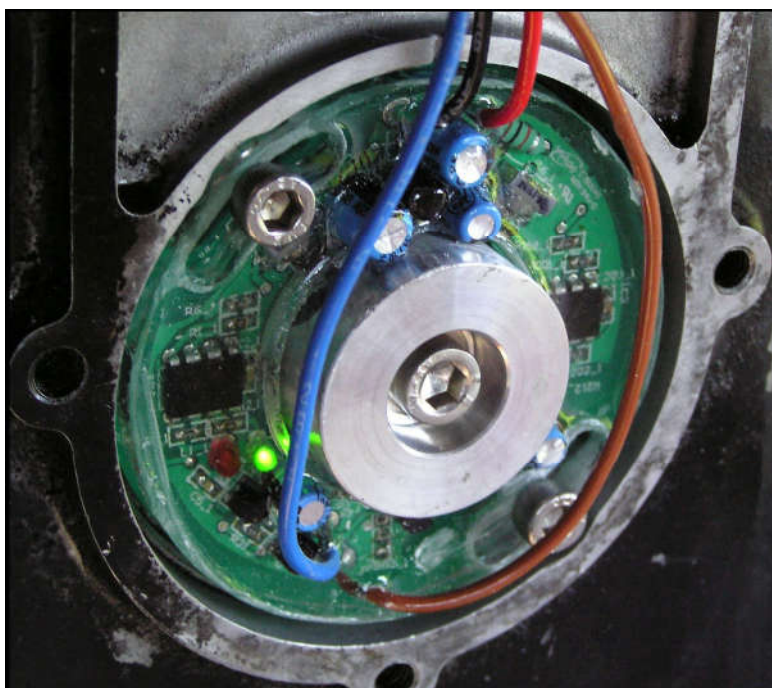

Once the first pass timing has been done as above – it should be checked and fine tuned a little more.

To Summarise:

Rotate the engine and note where the left and right RED LEDs turn OFF with regard to the FL and FR marks. Due to the residual magnetism of the flywheel there is some variation – the best approach is to ensure that the LED turn off points are equally spaced either side of the FR and LR marks.

- if the Left LED turns off a bit before the FL mark then try to get the Right LED to turn off a bit after the FR mark.
- if the Right LED turns off a bit before the FR mark then try to get the Left LED to turn off a bit after the FR mark.



- the two m5 screws can be loosened and the Hall Advancer assembly rotated slightly.

This can take a couple of goes and is not super critical – reasonably close is fine.

What you are trying to achieve is shown in the diagram below. Where the RED blocks show where the RED leds are on.

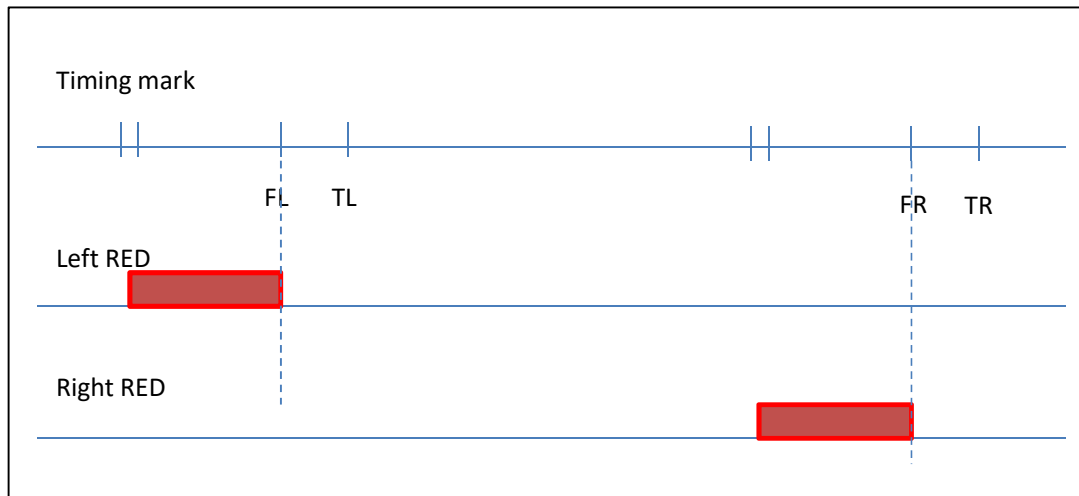

Rotate the engine and check that the turn on of the RED LED occurs near the Full Advance marks – these are a pair of lines before the FL and FR marks that indicate the stock full advance range.

When happy with the location – do the screw (bolt(s)) up snug – but not too forcefully that the potting breaks – be gentle – the thread-locker will help ensure things stay done up.

Notes:

- 1 Due to the slight asymmetry in the turn off position – you might need to tweak the idle up slightly – to get back to the stock idle speed – this is because one cylinder will be firing a touch late at idle. You may also notice a bit of additional vibration at idle as a result – neither of these is harmful and once you move off idle all is smoothed out.

If you really need to smooth this out – then rotating the pickup slightly so that the latest turn off is on the FL or FR mark is an option. Rather than ½ late ½ early balance between the sides around the FL and FR marks, put the latest one on the respective FR/FL mark and the other in advance of its mark.

- 2 With the fitting of the Hall effect sensor – the internal pickup coils become redundant and may be removed if the engine is open to perform other work. **PLEASE** note that the Right Hand Side pickup provides the **TIMING MARK**. If you remove the pickup



then a template must be used to allow you to set the timing. Such a template has been prepared by a couple of forum members and may be found on the [Rae-San Ignition Support page](#). It is a pdf that can be printed out onto some card or thick paper and provides a pointer that is aligned to provide the correct timing mark.

If you do remove the pickups – don't cut the leads off as if they are still functional they could be used to keep another bike on the road.

Run the Wires

Now that the timing position is set lets run the wires.

Note I'm assuming the High voltage coils on the Stator are no good – or possibly a G8 type stator has been fitted if desired. If the high voltage windings are still desired then two of the wires might need to be squeezed through each hole rather than run individually.

- Remove the two advance pickup wires with their bullet connectors and pull the wires out of the rubber bung.
- Cut the Blue and white wires from the stator high voltage coils – and remove these from the rubber bung also.
- Run the wires through the second rubber bung and up to the top as shown in the photos below.

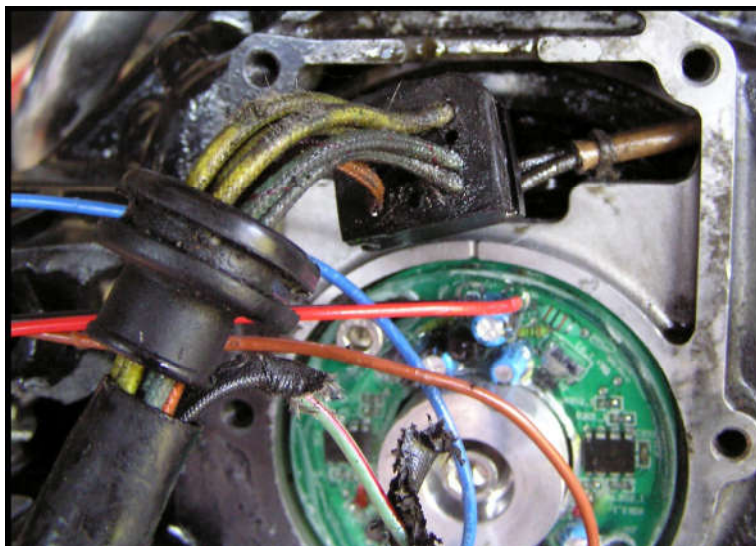

Position the wires out of the way of the spinning rotor and clear of sharp edges on the case.

Below is shown an option if you don't want to individual feed the wires through due to the bullet connectors and would rather cut a section out of the "grommet"

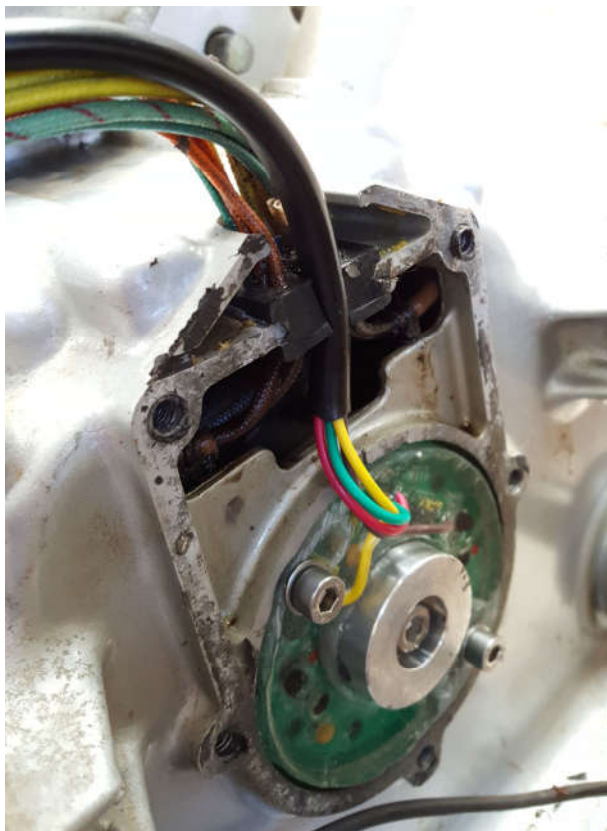
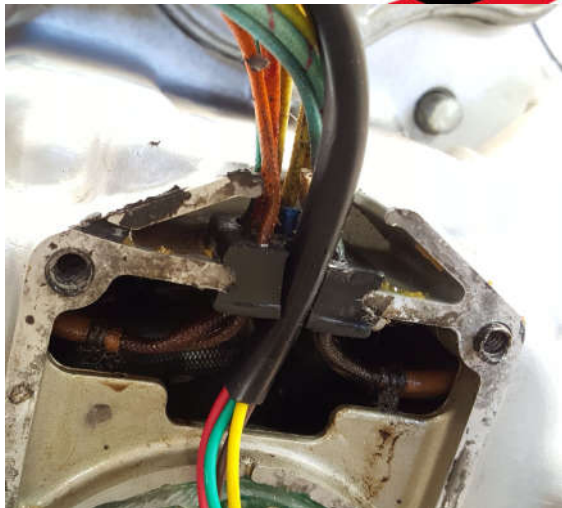



Below shows the wires exiting a the upper connector – ready for connection.

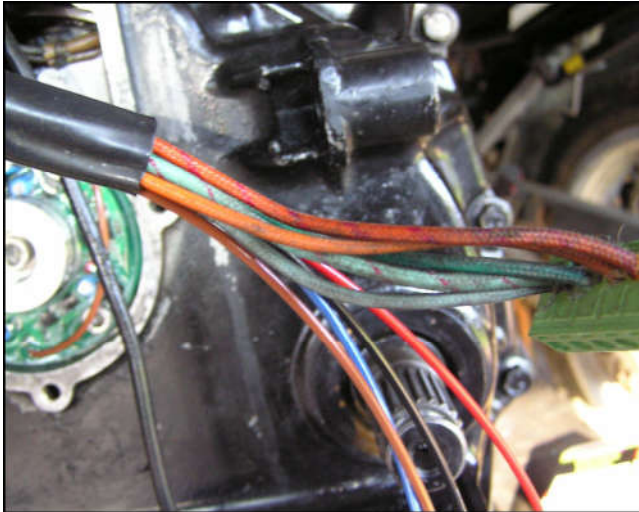

Install the rear cover plate with gasket – as shown below and the process is complete.

NOTE - there might be a bracing bracket across the rear cover plate - THIS SHOULD BE BENT BACK FLAT out of the way - otherwise it can trap and cut the wires - or rub on them and cut them. Please check this before bolting the cover on.



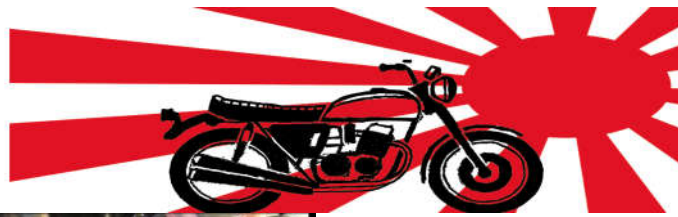

You may now install the engine back into the frame and proceed to the installation of the CDI Coil Driver.

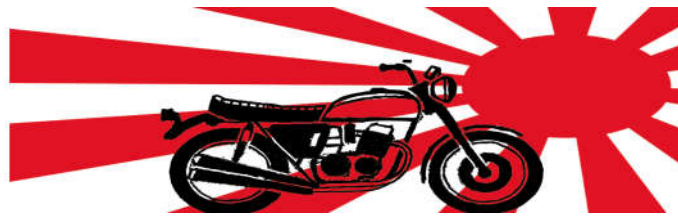

Installation – CDI Driver

The CDI Driver module consists of two GY6 DC-CDI modules plugged to a control module with connectors. This provides connection for the Hall Advancer power and trigger signals on the input side, and the connections to power, grounds and the CDI coils on the output side.

The DC-CDI modules internally generate the high voltage used to drive the Ignition coils from 12V. Two modules are used- one for each cylinder to provide for Redundancy and so that normal diagnostic swapping of the sides can be performed for diagnostic purposes as per the original setup.

The V3.0 CDI driver module is pictured below with connections labelled and coloured.

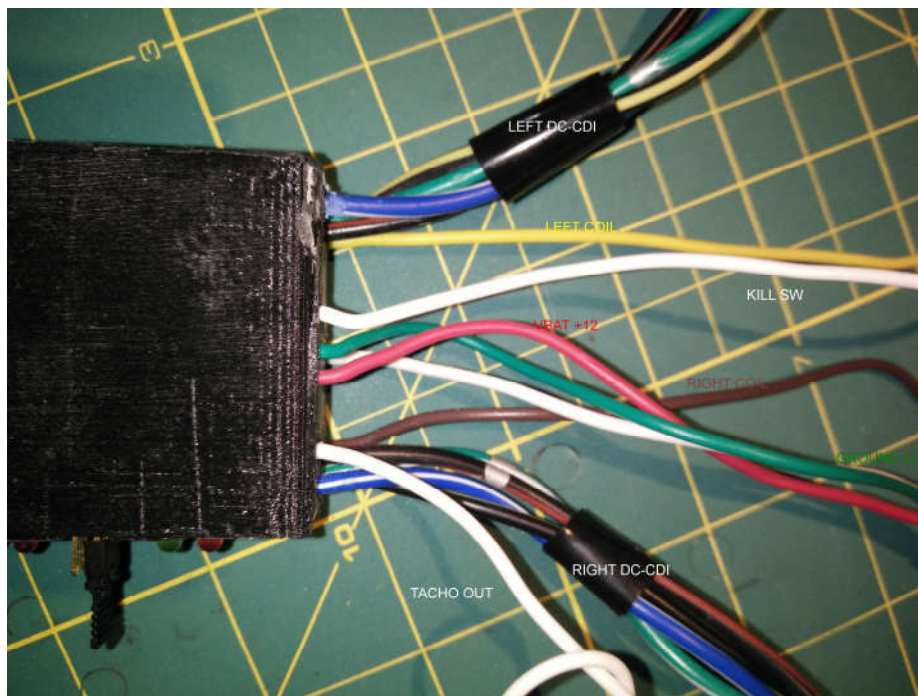

<u>Wire colour</u>	<u>Wire Function</u>
Red	+12V power in – switched power from the bike
Green + White to LUG	GROUND connection – bolt to Frame
Yellow	Left COIL
Brown	Right COIL
White – Adjacent Green	Kill Switch – Ground to Kill (Leds will still flash)
White – on its own near blue/white	Tacho Output option.



- Remove the Stock CDI box
- Place the CDI Driver in the space that was occupied by the Stock CDI box.
- Connect the DC-CDI (GY6) driver modules to the left and right connector sets.
- Connect the left and right CDI coil wires – YELLOW and BROWN.
- **Connect the Grounds LUG with a bolt to the Chassis**
- Connect the White Kill Switch wire to the Black/white Kill Switch wire.
- Connect the Power input to the Switched power in the Loom – the Black wire – this is often accessible at the rear brake switch.
- Connect the Hall connections to the Unit – Yellow – Yellow, Brown to Brown, Red to Red and Green to Green

Shown below is the connection of the power, coil and kill switch to the existing connectors on the bike.

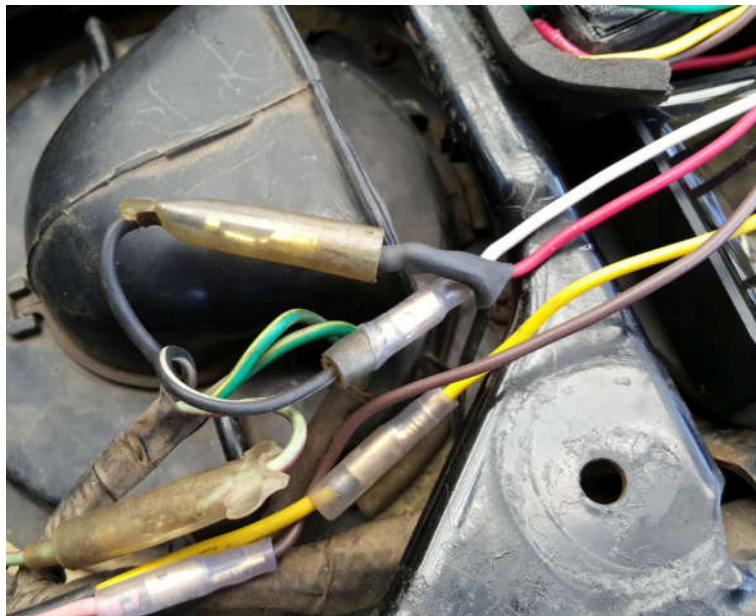

The next image shows a possible mounting arrangement although many arrangements are possible – this is just an idea. Note that the user has been advised to modify this arrangement to avoid the sharp bend / squashed arrangement of the four wires to the hall sensor (at the bottom of the controller). This arrangement over time with the sharp bend and vibration is likely to lead to broken wires – right where they enter the controller.

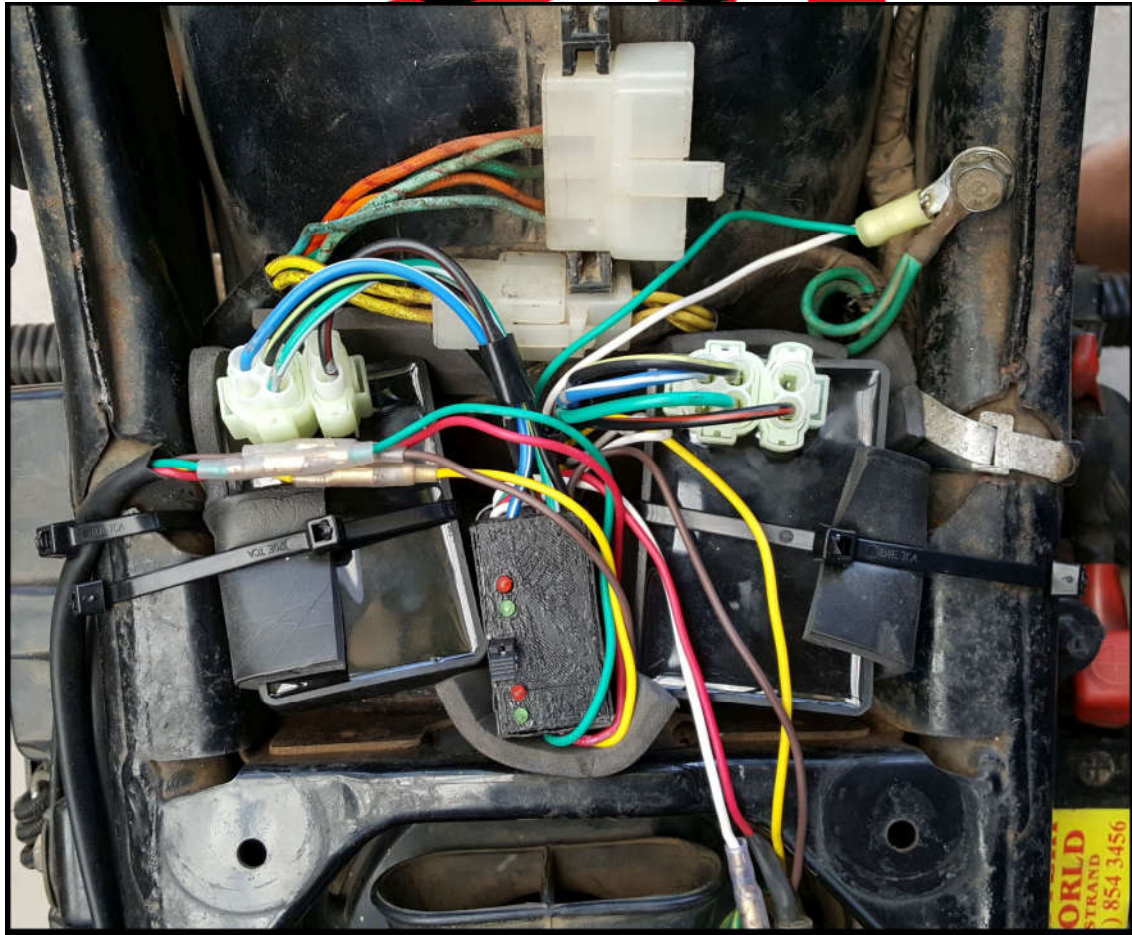
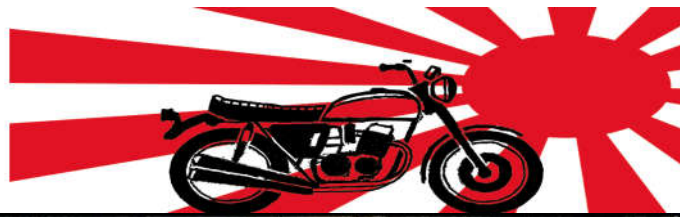



Installation Stock Pickup

The original CDI circuit draws all its power straight from the Stator using the high voltage windings to power the CDI. The new module operates like a TAI system instead and draws the power from the 12V of the bike. The current to power the modules is drawn from the switched power circuit of the bike (Black wire) and is relatively low – much less than a TAI system in general and increases with increasing RPM – as the charging capacity of the generator increases.

As a result it is safe to draw the ignition power straight from the +12V switched power, a separate relay based direct feed to the battery is not required as the maximum current draw is less than 2 Amps.

Shown below is the Stock Pickup unit fitted to the DC-CDI modules.

The connections to bike are the same as for the Hall System – the 8 way connector just plugs into the existing 8 way connector in place of the Old CDI.

The Two pin connector with the blue and white wire is left unconnected. If the blue and white wires are still functional then a dummy load can be fitted to preserve their operation. If they are faulty then there is no point.

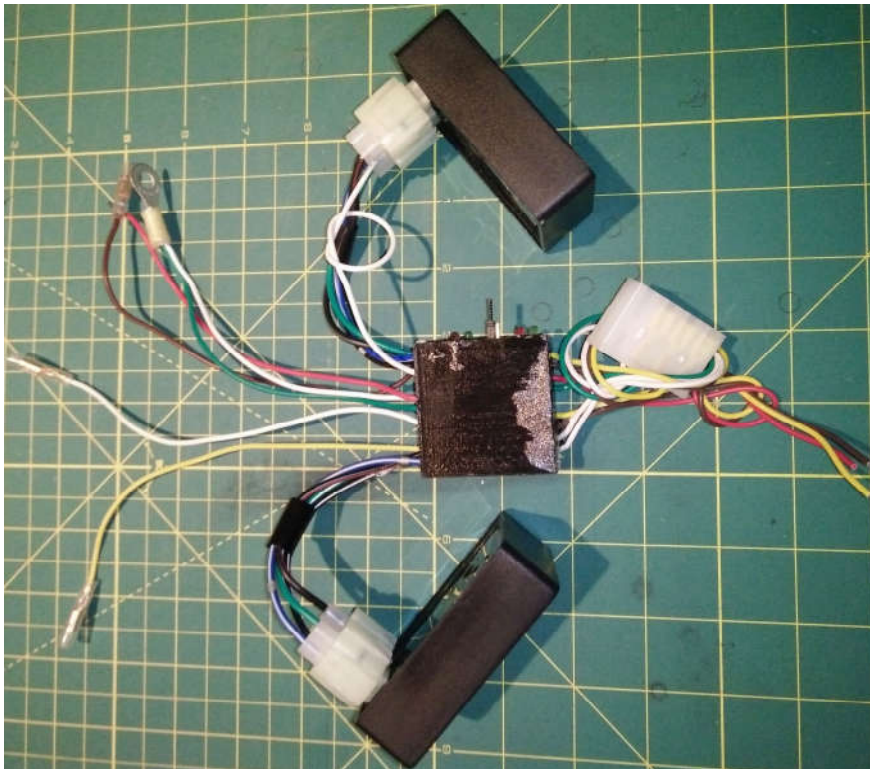



<u>Wire colour/ Module</u>	<u>Wire Function / Bike</u>
Red	+12V power in – switched power from the bike
Green + White to LUG	GROUND connection – bolt to Frame
Yellow	Left COIL
Brown	Right COIL
White – Adjacent Green	Kill Switch – Ground to Kill (Leds will still flash)
White – on its own near blue/white	Tacho Output option.
8 pin Female connector	Plugs into the 8 pin male connector
Unused or dummy load	2 pin blue / white connector

IgniTech Installation

Installation of the system to trigger an Ignitech is quite simple.

Install the Hall Effect sensor and Rotor as per the Hall Effect Installation earlier.

Connect the Hall Effect to the Ignitech Adaptor as shown below and plug the in Ignitech into the adaptor. You will need to provide 12V to the RED wire of the Hall, and ensure that the Ignitech ground on pin 5 of the 8 pin connector is connected to the bike ground.

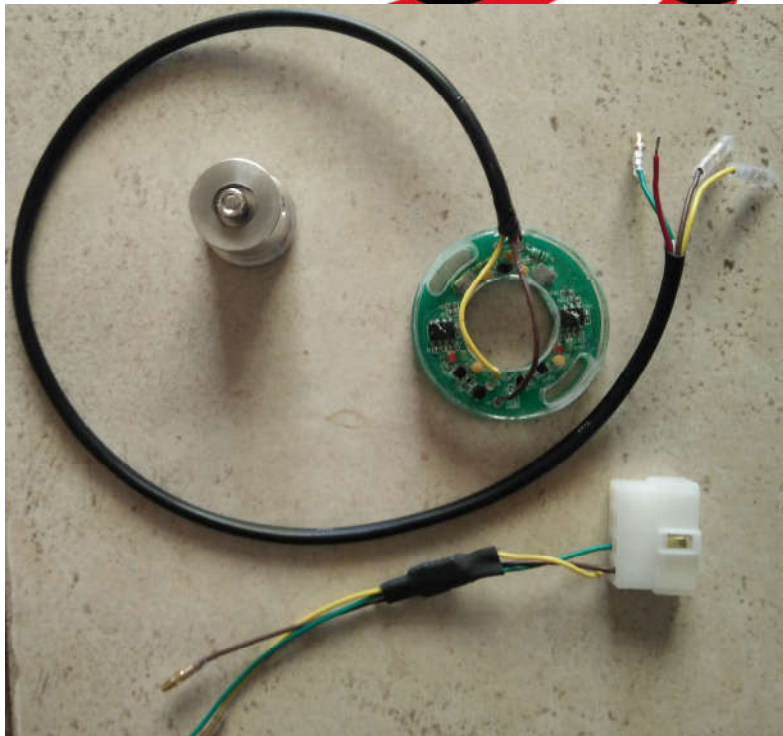

Ignitech Configuration

Connect the Ignitech to a serial connection and your computer –

Start the appropriate Ignitech Software (eg DCCDIP2_91.exe) and connector the Ignitech.

The input configuration of the needs to be changed to set the inputs to use standard type triggers – this is found on the bike tab: setup for Classic 1 lobe, 2 pickup, positive polarity.

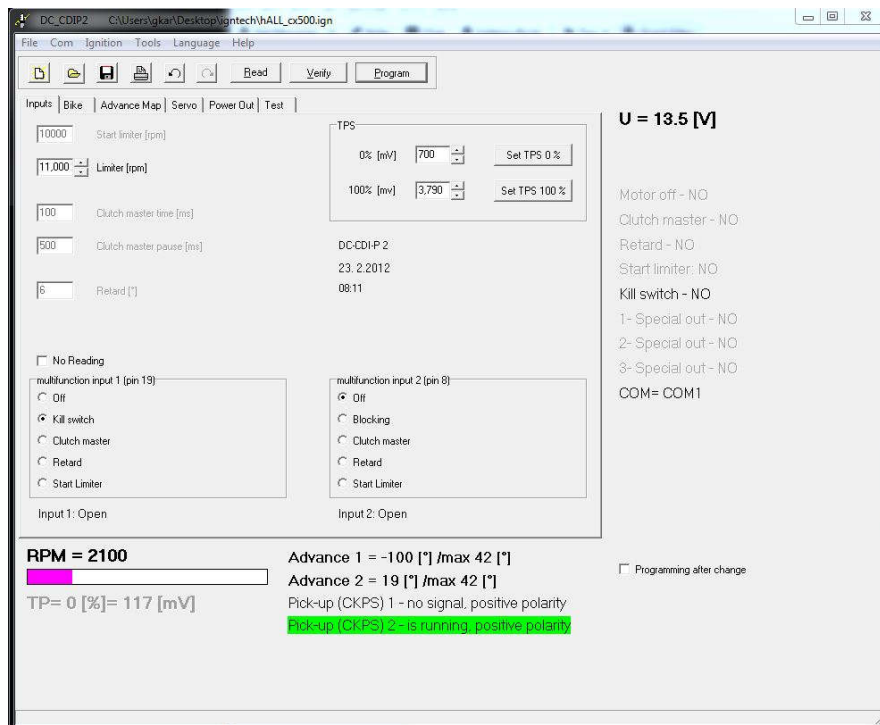
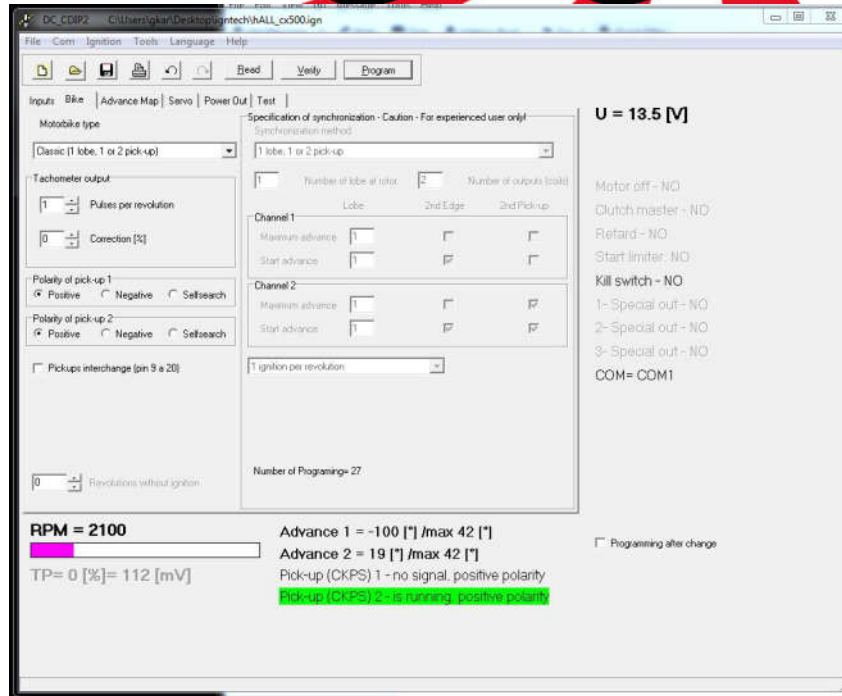
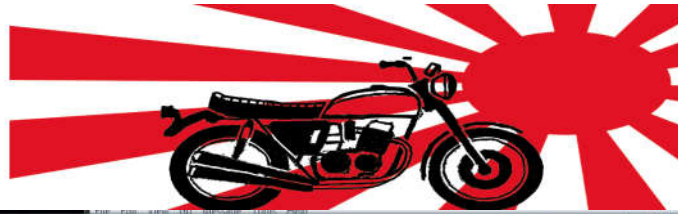

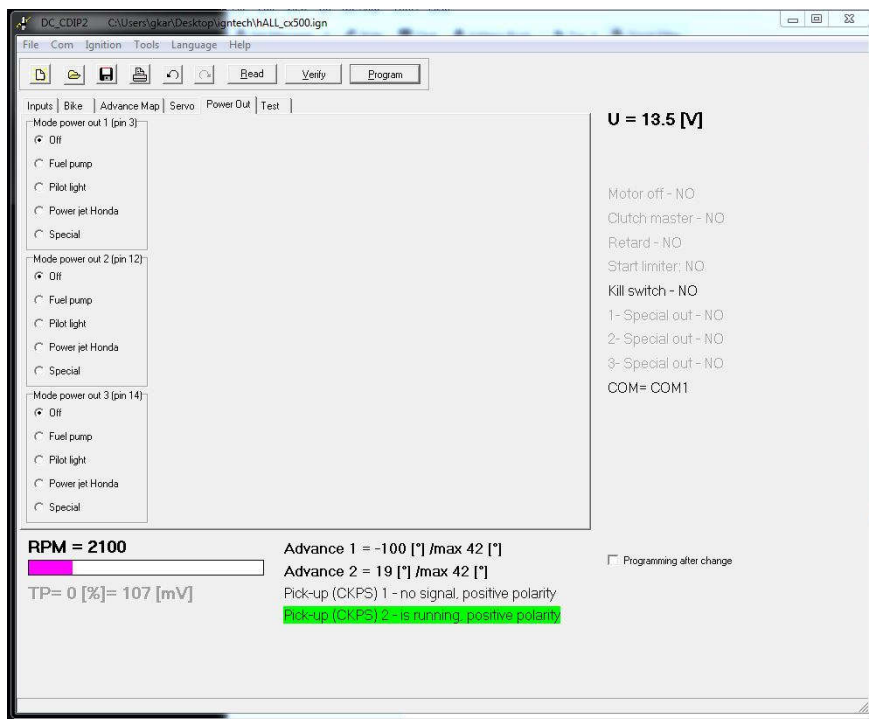
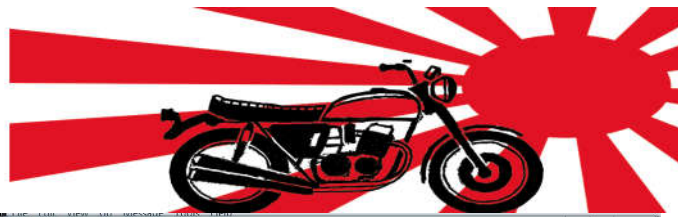

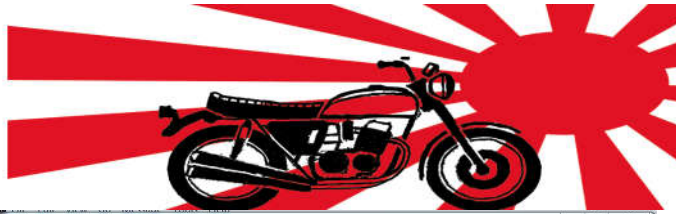

DC_CDIIP2 C:\Users\lgkar\Desktop\lgntech\hALL_co500.ign

File Com Ignition Tools Language Help

Read Verify Program

Inputs | Bike | Advance Map | Servo | Power Out | Test |

Servo enable

U = 13.5 [V]

Motor off - NO
Clutch master - NO
Retard - NO
Start limiter - NO
Kill switch - NO
1- Special out - NO
2- Special out - NO
3- Special out - NO
COM= COM1

Programming after change

RPM = 2100

TP= 0 [%]= 117 [mV]

Advance 1 = -100 [°] /max 42 [°]
Advance 2 = 19 [°] /max 42 [°]
Pick-up (CKPS) 1 - no signal, positive polarity
Pick-up (CKPS) 2 - is running, positive polarity

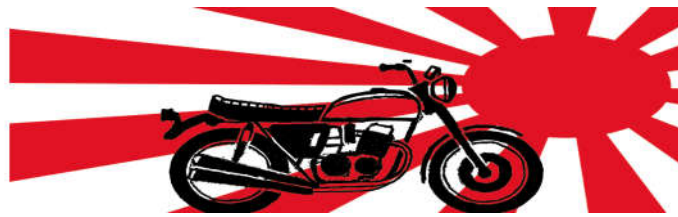

Jumper Settings

The Rae-San ignition Module contains a small number of configuration options which are set via the two jumpers – pictured below

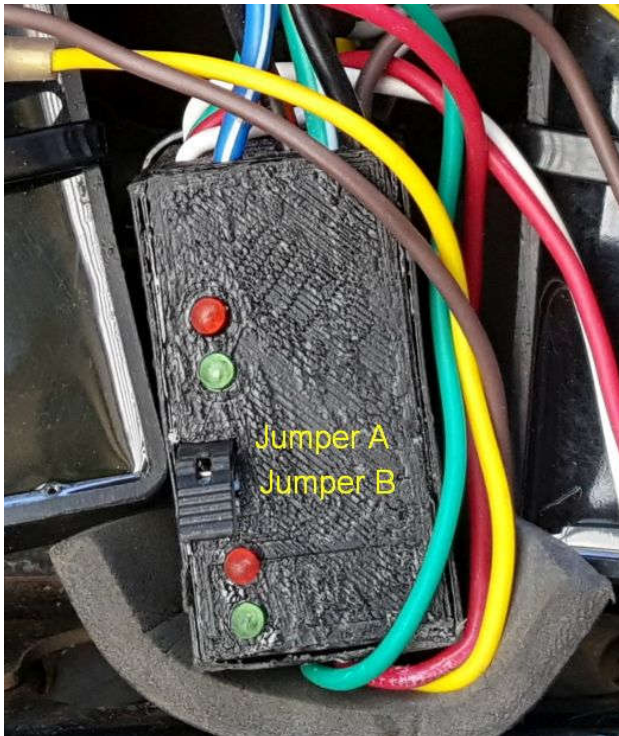

There are 4 ignition timing curves that may be selected from.

Jumper Settings

Jumper A	Jumper B	Function	Comment
Off	Off	Curve A	Default 15 @ 1900 – 37 deg @ 3900.
On	Off	Curve B	15 deg @ 1630 – 37 deg @ 3300.
Off	On	Curve C	15 deg @ 2300 - 37 deg @ 4580
On	On	Curve D	15 deg @ 1900 – 37 deg @ 5700

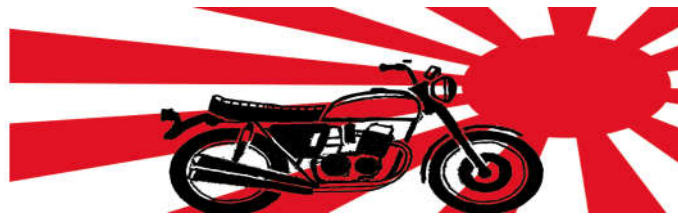

Timing Curves

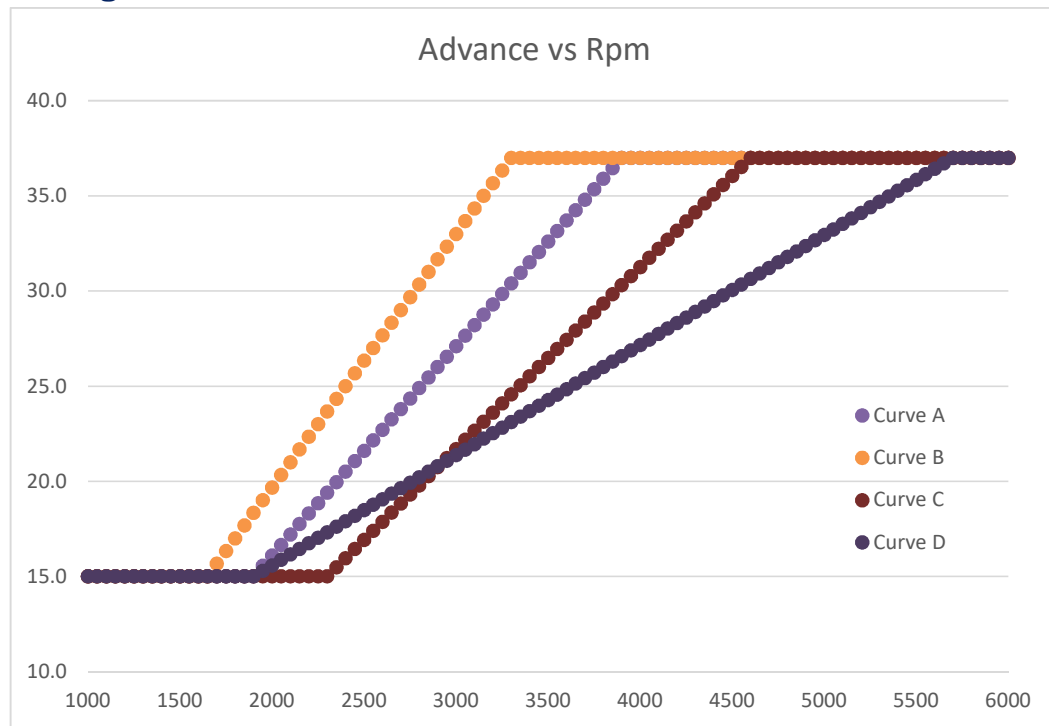

Curve A (Purple) 15 deg @ 1900 – 37deg @ 3900. The new default setting – better than original but still safe for higher altitude.

Curve B (Orange) 15 deg @ 1630 – 37 deg 3300 @ : This is more aggressive advance option – worth trying with better fuels.

Curve C (Brown) 15 deg @ 2300 - 37 deg @ 4580 : A little more aggressive than the original.

Curve D (Dark Blue) 15 deg @ 1900 - 37 deg @ 5700 : Conservative original CDI spec.

About Advance Timing –

A number of factors should be considered in your choice of advance curve, the most significant of these is the overall carburetion.

Stock OEM carbs -

The Original Honda Keihin carbs are arranged to run fairly lean – to get the best fuel economy and reduce emissions – This gets worse as altitude increases – or the air temperature rises due to the reduction of the oxygen density – hence the need to adjust the pilot screws for higher altitudes found in the manual

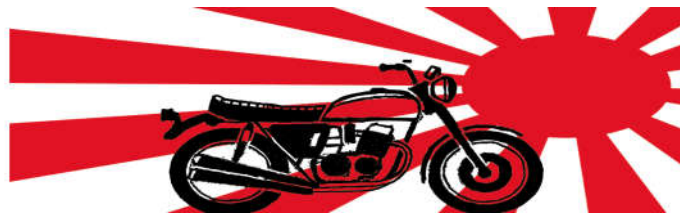

The problem with lean running is heat – the fuel burns hotter, your valves and pistons get hotter – too lean and you melt / break exhaust valves or burn holes in your pistons.

Re-jetted Stock with Pods?

The “standard” 120/90 is on the rich side and often is attempting to compensate for turbulent flow in the carburettor throat caused by the lack of an intake runner to the carb, and for partially blocked intake ports due to the cheaper pod filters design.

With correct pods – the suggested jetting is around 115-118 / 85 – 88. A larger pilot could also be beneficial – stock is 38, a 40 would be a good choice.

Running rich will keep things cooler, and allows the more aggressive curves to be run more safely.

Murrays Mikuni Carbs

These are set to run on the richer side – to get more HP rather than worry about fuel economy – so again the aggressive curves may be run.

Summary

Running **stock carbs**, with **stock advance** is just that – Stock. It is what Honda determined to be safe and conservative for most situations, with the advice to turn out the pilot jet screw for higher altitude running. This is **safest** but won't get you any gains.

As soon as you change the carbs, intake filters/ air-box, or advance curves you are in modified territory. What this means is you take the responsibility if something breaks, burns, explodes or does anything you don't expect or desire.

I provide you with tools that you may use at your own discretion and which may give you more horsepower or drivability but it is your responsibility as to how you use them.

My recommendations would be:

Stock setup : Curve D, Maybe C for low altitude.

Keihin OEM with Pod filters - 120/90 or similar jetting : Curve C or A

Murray's Mikunis : Curve A, Curve B low altitude option.

Using anything other than Curve D represents a modification as is done so at your own risk.

Having said all that - there are differences that can be felt. Happy Modding.

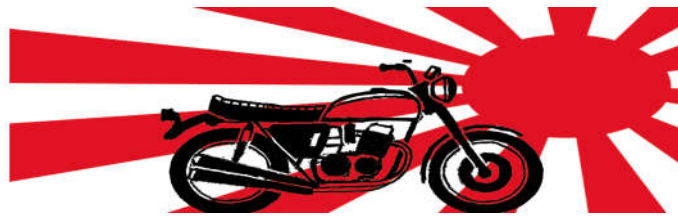

Factory Original Settings

There are a large number of CX variants with some variation in timings – the factory published timings are in the table below. Suitable Bikes for the modules in this manual are shaded in green.

You will need to check which motor you have fitted as many swaps have been performed – but if you have a CDI ignition the Rae-San system can be fitted.

It is also possible to fit the hall effect system to the TAI bikes – but that is beyond the scope of this document. – a slightly different setup is needed. These are shaded amber.

Model Name	Model nos	Base Adv Value	@ RPM	Final Adv value	@ RPM	No of boxes and locations	Connectors
CX400	CX500-	15	Up to 1500	45	3000	2 NEC igniters sidepanel	2 x 6 pin
CX500 ABZ	78-81 CX500-	15	Up to 1750-2250	37	5600-6000	CDI box under seat	8 pin CDI + 2 pin CDI power
CX500 Custom	80-81 PC01	15	Up to 1750-2250	37	5600-6000	CDI box under seat	8 pin CDI + 2 pin CDI power
CX500 C	82 CX500-	15	Up to 1500	45	3000	2 NEC igniters sidepanel	2 x 6pin
CX500 Custom	82 PC01-	15	Up to 1500	40	2780	2 NEC igniters sidepanel	2 x 6pin
CX500E	PC06-	15	Up to 1500	45	3000	2 NEC igniters sidepanel	2 x 6pin
GL500		15	Up to 1500	45	3000	2 NEC igniters sidepanel	2 x 6pin



CX650E	RC12-	15	Up to 1500	45	3000	2 NEC igniters sidepanel	2 x 6pin
CX650 Custom		15	Up to 1500	40	3500	2 NEC igniters sidepanel	2 x 6pin
GL700		15	Up to 1500	45	3000	2 NEC igniters sidepanel	2 x 6pin

Operation

In operation there should be nothing to do – the module should behave similarly to the original ignition. (or better)

Recommended Coils

The ignition module is suited to CDI coils in the < 1 ohm range. The Original coils fitted to the CX CDI models are suitable candidates. There are also a number of aftermarket replacement coils that are suitable and readily available on Ebay.

CDI Coil On Plugs – with a resistance less < 1 ohms may be able to be used.

Connections

The connection information is shown on the diagrams – note that a GOOD ground to chassis should be provided to the main power connection – this carries the coil current and the shorter the better.

A ground connection should also be provided to the Chassis Ground connection – this is not a high current connection but is important to minimise noise and cross-firing as it provides a ground to the metal case of the module and shields the electronics from the spark noise generated – especially on systems where no plug resistors are fitted.

Hall Setup

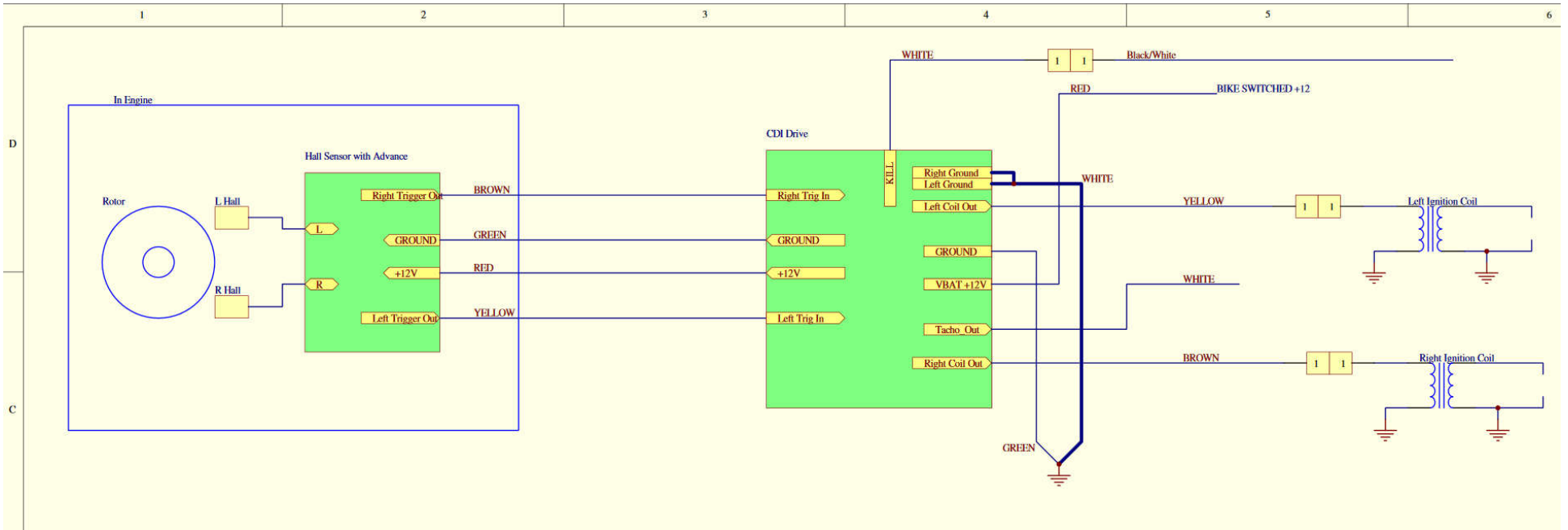

Stock

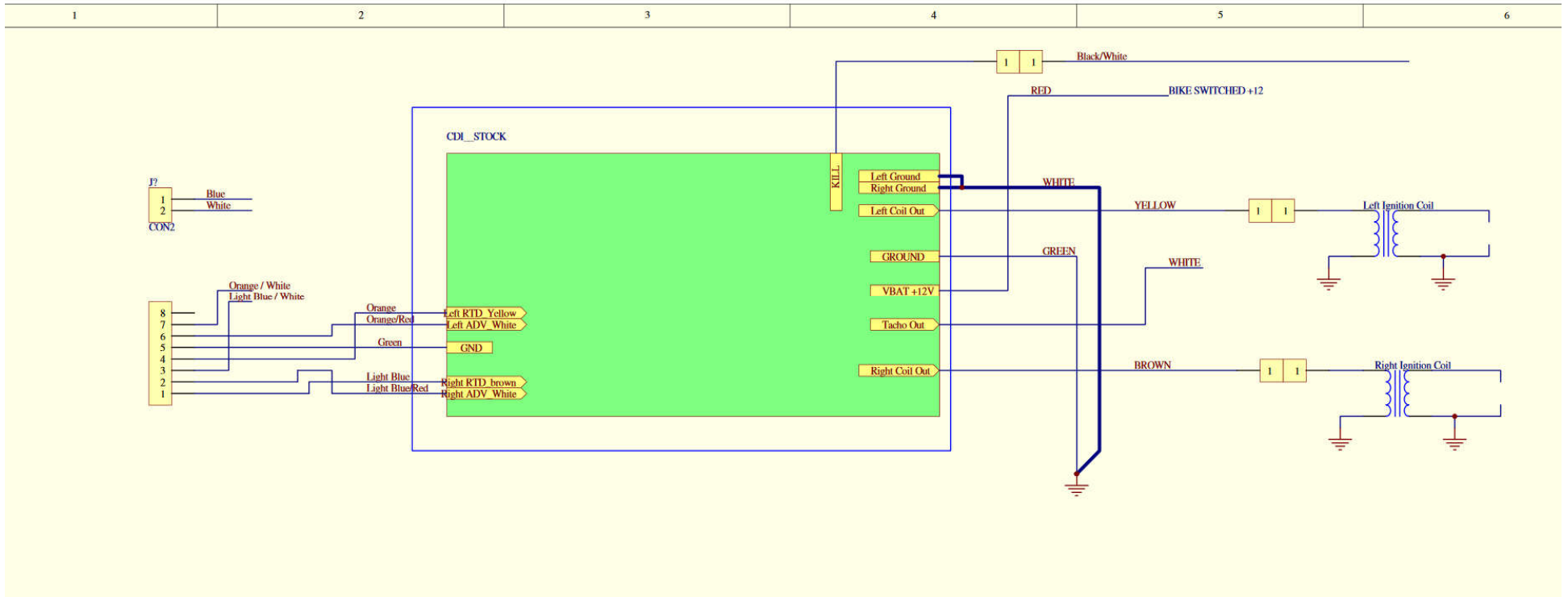

Ignitech with Hall

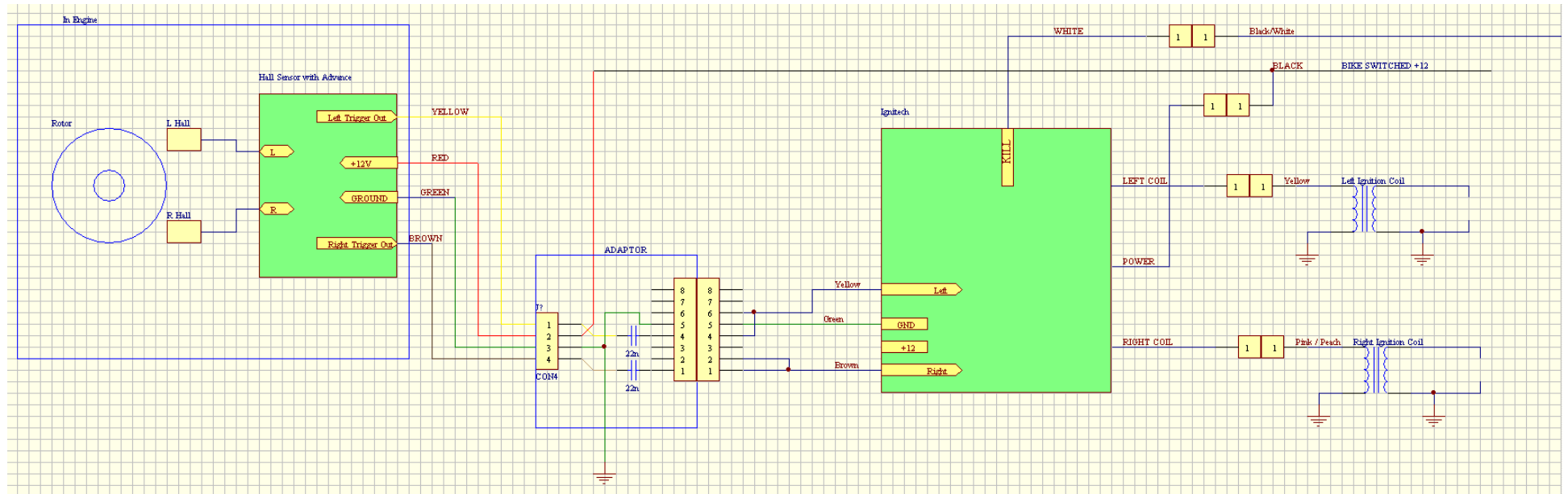

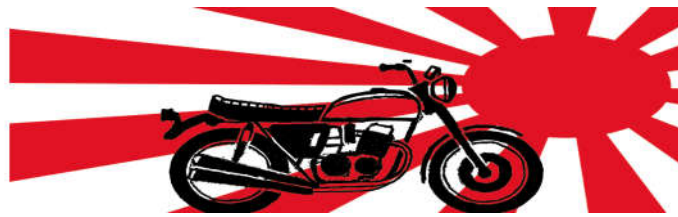

MOTORCYCLE PRODUCT DISCLAIMER

Motorcycling is an inherently dangerous activity, which may result in personal injury and / or death. While Rae-San (and/or Entities Trading as Rae-San) products are designed to offer superior riding comfort and performance, no product can offer complete protection from injury or damage to individuals and property in case of fall, loss of control or otherwise. You should wear appropriate protective equipment, obey all traffic laws, regulations and use good judgment. Never take alcohol or drugs (legal or illegal) before riding. Always inspect your motorcycle before riding, and read your owners manual. You should be familiar with the wide range of foreseeable hazards of motorcycling and decide whether to assume the risks inherent in such activity, which include damage to property, serious injury to you or others and death.

RAE-SAN (AND/OR ENTITIES TRADING AS RAE-SAN) DISCLAIMS ANY RESPONSIBILITY FOR INJURIES OR DAMAGES INCURED WHILE USING ANY OF ITS PRODUCTS. RAE-SAN (AND/OR ENTITIES TRADING AS RAE-SAN) MAKES NO GUARANTEES OR REPRESENTATIONS, EXPRESSED OR IMPLIED, REGARDING MATERIALS AND WORKMANSHIP OR THE FITNESS OF ITS PRODUCTS FOR ANY PARTICULAR PURPOSE, FURTHER RAE-SAN (AND/OR ENTITIES TRADING AS RAE-SAN) MAKES NO GUARANTEES OR REPRESENTATIONS, EXPRESSED OR IMPLIED, REGARDING THE EXTENT TO WHICH ITS PRODUCTS PROTECT INDIVIDUALS OR PROPERTY FROM INJURY OR DEATH OR DAMAGE. RAE-SAN (AND/OR ENTITIES TRADING AS RAE-SAN) PRODUCTS MUST BE INSTALLED AND REPAIRED BY A TRAINED PROFESSIONAL. RAE-SAN (AND/OR ENTITIES TRADING AS RAE-SAN) DISCLAIMS ANY RESPONSIBILITY FOR INJURIES, DEATH OR DAMAGES DUE TO IMPROPER INSTALLATION OF ITS PRODUCTS. ANY ACTUAL ATTORNEY FEES FOR ANY UNSUCCESSFUL CLAIM AGAINST SELLER TO BE PAID BY PLAINTIFF/COUNTER-CLAIMANT.

Modification of a motorcycle by fitting the devices obtained from Rae-San (and/or entities trading as Rae-San) may void manufacturer's warranty, state and federal laws and render insurance void. It is the responsibility of the motorcycle owner to be familiar with these laws. Fitting of any product from Rae-San (and/or entities trading as Rae-San) constitutes acceptance of the responsibility and consequences of any legal, insurance, or warranty breach by the motorcycle owner. Furthermore fitting of any device constitutes acceptance and agreement to indemnify Rae-San (and/or entities trading as Rae-San) of all damages and liabilities that may arise in the event of accident, misfortune or failure of a device.

12 MONTH LIMITED WARRANTY AND LIABILITY DISCLAIMER

Rae-San (and/or Entities Trading as Rae-San) warrants this product free from defects in material or workmanship for a period of 12 months from the date of purchase, except as noted. The product warranty does not cover damage caused by misuse or abuse; accident; the attachment of any unauthorized accessory; alteration to the product, improper installation, exposure to harsh weather and/or chemicals, lack of proper maintenance, lubrication, or any other conditions that are beyond



the control of Rae-San (and/or Entities Trading as Rae-San). Rae-San (and/or Entities Trading as Rae-San) shall not be responsible for any type of incidental, consequential, or special damages. All implied warranties, including but not limited to those warranties of fitness and merchant accountability, are limited in the total duration to 12 months from the original purchase date. If the warranty occurs within 30 days from the date of purchase, please contact the dealer the product was purchased from. Over 30 days from the date of purchase, please contact Rae-San (and/or Entities Trading as Rae-San) direct at Rae-San@Rae-San.com. Customer must contact Rae-San (and/or Entities Trading as Rae-San) prior to sending warranty product. Claims for lost shipment, damaged shipments, or other problems regarding freight must be made directly to the responsible carrier. Warranty is solely through Rae-San (and/or Entities Trading as Rae-San). Service to our products by anyone other than Rae-San (and/or Entities Trading as Rae-San) authorized installation centers voids warranty. Rae-San (and/or Entities Trading as Rae-San) disclaims any and all liability for consequential or incidental damages. Rae-San (and/or Entities Trading as Rae-San) will not be held responsible for personal damage, bodily harm or any other legal matters.